



# SpireMag™ Series

## MAG888 Electromagnetic Flowmeter

### User's Manual

*UMMAG888KD-403-5*

December 13, 2012

Revised March 24, 2014

#### SPIRE METERING TECHNOLOGY LLC

15 Craig Road

Acton, Massachusetts 01720

United States of America

Tel. +1 978 263 7100

Fax +1 978 418 9170

E-mail: [support@spiremt.com](mailto:support@spiremt.com)

Website: [www.SpireMT.com](http://www.SpireMT.com)

The following conventions are used through this manual:

**WARNING!**

**Read the declaration carefully before starting any other action!**

**Local safety regulations must be applied!**

**CAUTION!**

**Attention! Damage could occur to the device if handled inappropriately.**

For questions, please call us at +1 978 263 7100 or email us at [support@spiremt.com](mailto:support@spiremt.com).

## Contents

<b>1. Introduction</b> .....	<b>1</b>
§1.1 Preface .....	1
§1.2 Features .....	2
§1.3 Dimensions and Pressure Ratings.....	3
§1.4 Flow Measurement Principle.....	4
§1.5 Typical Applications .....	5
§1.6 Product Identification .....	5
§1.7 Specifications .....	6
<b>2. Installation and Measurement</b> .....	<b>8</b>
§2.1 Unpacking .....	8
§2.2 Installation Considerations .....	8
§2.2.1 Installing the Unit .....	8
§2.2.2 Installing the Flowcell.....	8
§2.3 Wiring.....	9
§2.3.3 Characteristic and connection of cable .....	12
§2.3.4 Digital output and calculate .....	15
§2.3.5 Simulation signal output and calculate .....	18
§2.3.6 Other Electrical Connections .....	20
§2.5 Keypad .....	21
§2.6 Quick Start Menu Navigation.....	22
<b>3. Menu Windows &amp; Details</b> .....	<b>24</b>
§3.1 Parameter Settings Configuration and Access Passwords .....	24
§3.2 Table of Parameter Setting Menu.....	24
§3.3 Parameter Details .....	26
<b>4. Warranty and Services</b> .....	<b>31</b>
§4.1 Warranty .....	31
§4.2 Service .....	31
§4.3 Software Upgrade Service.....	32
<b>Appendixes</b> .....	<b>33</b>
Appendix A MODBUS COMMUNICATION PROTOCOL.....	33
Appendix B HART COMMUNICATION PROTOCOL .....	38
Appendix C PROFIBUS COMMUNICATION PROTOCOL .....	39
Appendix D EARTH GROUNDING.....	40
Appendix E FLOW SENSOR INSTALLATION RECOMMENDATIONS.....	42



## 1. Introduction

### §1.1 Preface

The SpireMag Series MAG888 is designed to be installed in a fixed location for long-term high-accuracy flow measurement.

Operation of the MAG888 flowmeter is based on the electromagnetic induction law of Faraday. The MAG888 flowmeter is used to measure the volume flow of conductive fluids in a closed pipeline. Examples of applicable liquids are: water, salt water, sewage, pulps, slurry, acid, alkali, or any mixture of liquids and solids which have a specific minimum of electric conductivity. The SpireMag Series MAG888 is widely used in municipal and industrial liquid processes which include wastewater treatment, irrigation, pharmaceutical, chemical, metallurgical mining, and food and beverage.

Manufactured under strict standards, the MAG888 is produced to cover a broad range of crucial applications. The MAG888's construction from high grade steel and weatherproof design, ensure the unit will remain both reliable and robust. With a microprocessor and exclusive integrated circuit, Spire Metering's electromagnetic flowmeter has the advantages of reliable performance, high accuracy, easy to use, and more. The Pulse, RS-232, RS-485, PROFIBUS, HART, BACnet or LonWorks communication interfaces together with MODBUS support and power surge protection makes the MAG888 an ideal device for reliable flowmeter networking.

## §1.2 Features

<p>*Structure Type: Integral type or remote type</p> <p>* Accuracy: Standard version: <math>\pm 0.5\%</math> of reading High-accuracy version: <math>\pm 0.25\%</math> of reading Accuracy not affected by variation of flow density, viscosity, temperature, pressure and conductivity</p> <p>* Flow measuring range: 0.1m/s to 15m/s (0.3ft/s to 49ft/s), bi-directional</p> <p>* Display and Buttons: Large LCD display backlight. Displays the instantaneous flow, total flow, and alarm.</p> <p>* Totalizer: Three built-in totalizers: forward flow totalizer, reverse flow totalizer and net totalizer</p> <p>* Security: Keypad can be locked with password</p> <p>* No pressure drop, no disturbance to the flow</p> <p>* Medium Temperature: - Integral Type: <math>-10^{\circ}\text{C} - +80^{\circ}\text{C}</math> (<math>14^{\circ}\text{F} - 176^{\circ}\text{F}</math>) - Remote Type: Neoprene &amp; Polyurethane Liner: <math>-10^{\circ}\text{C} - +80^{\circ}\text{C}</math> (<math>14^{\circ}\text{F} - 176^{\circ}\text{F}</math>); PTFE Liner: <math>-10^{\circ}\text{C} - +150^{\circ}\text{C}</math> (<math>14^{\circ}\text{F} - 302^{\circ}\text{F}</math>)</p> <p>* Ambient Temperature: <math>-10^{\circ}\text{C} \sim +60^{\circ}\text{C}</math></p> <p>* Ambient Humidity: 5 ~ 90% RH (relative humidity)</p> <p>* Medium Electrical Conductivity: <math>\geq 5\mu\text{s}/\text{cm}</math></p> <p>* Protection Class: - For Main Unit: IP65 (outdoor) - For Sensor: IP65 (outdoor) or IP68 (submersible, only for remote type)</p> <p>*Power Supply: 85VAC-250VAC; 20VDC-36VDC Dissipation Power: &lt; 20W</p>	<p>* Electrode Materials: 316L SS, Hastelloy B, Hastelloy C, Titanium or Tantalum</p> <p>* Sensor Material: - Measuring tube: stainless steel - Housing: carbon steel or stainless steel - Flange type: ANSI #150 or DIN - Flange Material: carbon steel or stainless steel</p> <p>* Flow direction indication: Measuring both forward and reverse flow and recognizing its direction.</p> <p>* Analog Output: Isolated 0~10mA/4-20mA. Load resistor: 0-1.5K<math>\Omega</math> for 0-10mA, 0-750<math>\Omega</math> for 4-20mA</p> <p>* Frequency output: Forward &amp; reverse flow output with the frequency range of 1~5000Hz. External voltage &lt;35V, output current &lt; 250mA when the transistor is turned on.</p> <p>* Pulse Output: OCT circuit, used for forward or reverse flowrate Pulse frequency: &lt; 5000cp/s. Pulse width: 10ms, 20ms, up to 400ms, or 50% occupancy. External voltage: &lt;35V. Maximum output current: &lt;250mA</p> <p>* Alarm Output: Two isolated Open Collector Transistor (OCT) outputs for alarm signals Can be activated when the pipe is empty, the excitation circuits are broken or the volume of flow rate exceeds the value of designed limits</p> <p>* Integrated 16-bit MCU (microcontroller), robust by nature, provides fully digital processing and high noise resistance.</p> <p>* Communication: RS232, RS485/MODBUS, PROFIBUS, HART, BACnet or LonWorks Communication selectable</p> <p>* Wireless is available upon request</p>
--	--

**§1.3 Dimensions and Pressure Ratings**

DN size	Nominal Pressure	Dimension(mm)					Weight	
		L	D	H1	H2	H3	Compact	Remote
15	4.0	200	95	155	285	215	7.5	8.5
20		200	105	160	290	220	8.5	9.5
25		200	115	165	295	225	9	10
32		200	140	180	310	240	10.5	11.5
40		200	150	190	320	250	11	12
50		200	165	200	330	260	13	14
65	2.5	250	185	220	350	280	15	16
80		250	200	240	370	300	17	18
100	1.6	250	235	250	380	310	19	20
125		250	270	280	410	340	23	24
150		300	300	320	450	380	28	29
200	1.0	350	340	380	510	440	36	37
250		450	395	430	560	490	51	52
300		500	445	490	620	550	71	72
350		500	505	550	680	610	82	83
400		500	565	600	730	660	99	100
450		550	615	640	770	700	114	115
500		550	670	700	830	760	134	135
600		600	780	800	930	860	164	165
700	0.6	700	860	895	1025	955	439	440
800		800	975	1015	1145	1075	549	550
900		900	1075	1115	1245	1175	659	660
1000		1000	1175	1230	1360	1290	814	815
1200		1200	1405	1450	1580	1510	879	880
1400		1400	1630	1630	1760	1690	1239	1240
1600		1600	1830	1830	1960	1890	1559	1560
1800		1800	2045	2045	2175	2105	2089	2090
2000		2000	2265	2265	2395	2325	2614	2615

*Note: For different pressure rating, the dimension may be different. Please contact support@spiremt.com for more information.*

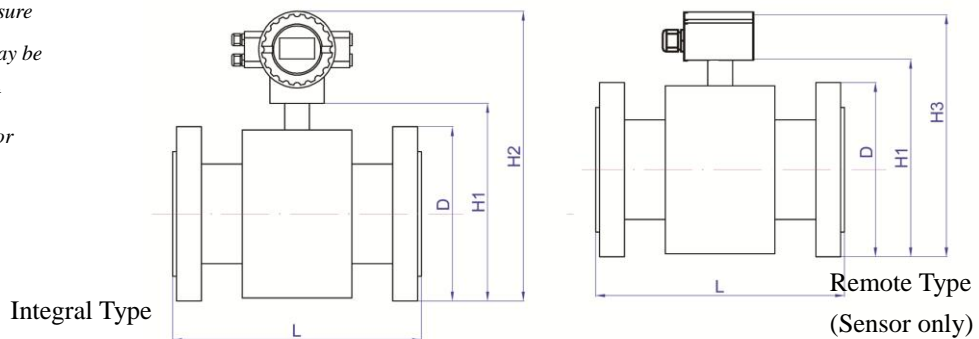

### §1.4 Flow Measurement Principle

The Spire Metering Technology's MAG888 electromagnetic flowmeter is designed to measure the velocity of a conductive liquid within a closed conduit. It uses Faraday's law of induction which states that a conductor moving in a magnetic field induces an electrical voltage. The sensor is mainly composed of a measuring tube with an isolating liner, a pair of electrodes, a pair of coils and an iron core to produce a working magnetic field. With the flowing fluid as the moving conductor and measuring-electrodes inside the flow-cell wall, the MAG888 detects an induced voltage which is proportional to the flow velocity. These velocity measurements are virtually independent of pressure, density, temperature and viscosity. Because of these operating principles, accurate measurements can be made of fluids containing solids such as ore slurry, and cellulose pulp.

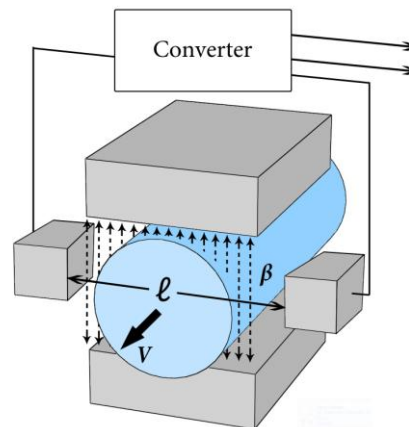

Figure 1.3 Principle of Electromagnetic Flowmeter

In accordance with Faraday's law of induction, a voltage  $\mathcal{E}$  is generated in the magnetic field  $B$  due to a conductive liquid moving at velocity  $v$  is thus given by:

$$\mathcal{E} = -Blv,$$

where  $l$  is the distance between electrodes in the magnetic flow meter. This law can be applied to flowmeter systems because many fluids are conductive to a certain degree. The voltage quantity generated by ions is transmitted as a 4-20mA signal that can measure various flow characteristics. The signal is handled by a high speed CPU and advanced signal processing technology to ensure a wide measuring range.



### **§1.5 Typical Applications**

The MAG888 flowmeter can be applied to a wide range of pipe flow measurements. Applicable liquids include pure liquids as well as mixtures of liquids and solids which have a minimum of electric conductivity. Examples are:

- Water (hot water, chilled water, city water, sea water, waste water, etc.);
- Sewage with particle content;
- Chemicals (glycol, alcohol, acids, etc.);
- Plant effluent;
- Beverage, liquid food;
- Ultra-pure liquids;
- Solvents and other liquids

Applications sorted by industry / process are:

- Water and waste water management;
- Water and waste water treatment plants;
- Power plants, such as nuclear power plants and hydraulic power plants;
- Mining and metallurgy plants;
- Chemical process monitoring and control;
- Pulp and paper process monitoring and control;
- Food and beverage processing;
- Marine maintenance and operation;
- Energy supply and production systems, such as geothermal system, HVAC, BMS, etc
- Flow measurement networking.

### **§1.6 Product Identification**

The MAG888 series flowmeter comes with two variations: Integral Type and Remote Type. The Integral Type has the electronic transmitter and the flow sensor integrated in one package. On the other hand, the Remote Type has the electronic transmitter and the flow sensor separated.

Each MAG888 flowmeter has a unique product identification number or ESN (electronic serial number) written into the software that can only be modified with a special tool by the manufacturer. In case of any hardware failure, please provide this number which is also located on the PCB below the wiring terminals.

## §1.7 Specifications

<b>Flow Velocity</b>	0.1m/s to 15m/s (0.3ft/s to 49ft/s), bi-directional
<b>Accuracy</b>	Standard version: $\pm 0.5\%$ of reading High-accuracy version: $\pm 0.25\%$ of reading Accuracy not affected by variation of flow density, viscosity, temperature, pressure and conductivity
<b>Display and Buttons</b>	Large LCD display with backlight. Display the instantaneous flow, total flow, and alarm.
<b>Totalizers</b>	Three built-in totalizers: forward flow totalizer, reverse flow totalizer and net totalizer
<b>Security</b>	Keypad can be locked with password
<b>Output Signals</b>	
<ul style="list-style-type: none"> <li>Analog Output</li> </ul>	Bi-directional, isolated 0 ~ 10mA / 4-20mA. Load resistor: 0-1.5K $\Omega$ for 0-10mA, 0-750 $\Omega$ for 4-20mA
<ul style="list-style-type: none"> <li>Frequency Output</li> </ul>	Forward and reverse flow output with the frequency range of 1 – 5000Hz. The external voltage must be lower than 35V and the max output current must be 250mA when the transistor is turned on.
<ul style="list-style-type: none"> <li>Alarm Output</li> </ul>	Alarm output: Two isolated Open Collector Transistor (OCT) outputs for alarm signals. The external voltage must be lower than 35V and the max output current must be 250mA when the transistor is turned on. Alarm will be activated when the pipe is empty, the excitation circuits are broken or the volume of flow rate exceeds the value of designated limits.
<ul style="list-style-type: none"> <li>Pulse Output</li> </ul>	The OCT circuit is used for forward or reverse flowrate output. The upper frequency of the output pulse can be up to 5000Hz. The relevant value of pulse is from 0.1m <sup>3</sup> /p to 1000m <sup>3</sup> /p. Pulse width can be set to 10ms, 20ms, up to 400ms, or, 50% occupancy. The external voltage must be lower than 35V and maximum output current must be 250mA when the transistor is on.
<b>Flow Direction Indication</b>	The converter (main unit) is capable of measuring both forward and reverse flow and recognizing its direction. The converter outputs 0V low level for forward flow, while +12V high level for reverse flow.
<b>Communication</b>	RS232, RS485/MODBUS, PROFIBUS or HART Communication selectable. RS485 interface has opto-isolation rated for 1500V
<b>Protection Class</b>	

<ul style="list-style-type: none"> <li>For electronic box</li> </ul>	IP65 (outdoor). IP67 optional.	
<ul style="list-style-type: none"> <li>For sensor</li> </ul>	IP65 (outdoor) or IP68 (submersible, only for remote type)	
<b>Nominal Pressure</b>	DN15 – DN100 (1/2” – 4”): 2.5MPa (362psig) DN125 – DN250 (5” – 10”): 1.6MPa (232psig) DN300 – DN1000 (12” – 40”): 1.0MPa (145psig) DN1200 – DN2000 (48” – 80”): 0.6MPa (87psig) Higher pressure rating is available upon request	
<b>Lining Material</b>	Rubber, PTFE, Polyurethane	
<b>Electrode Type</b>	General type, scraper type or replaceable type	
<b>Electrode Material</b>	316L SS, Hastelloy B, Hastelloy C, Titanium, Tantalum	
<b>Sensor Material</b>		
<ul style="list-style-type: none"> <li>Measuring Tube</li> </ul>	Stainless Steel	
<ul style="list-style-type: none"> <li>Housing</li> </ul>	Carbon steel as standard offer. Stainless steel available upon request	
<ul style="list-style-type: none"> <li>Flange</li> </ul>	Carbon steel as standard offer. Stainless steel available upon request	
<b>Pipe Connection</b>	DIN flange as standard offer	ASME ANSI flange
	Clamped Type	Flange Wafer type
<b>Medium Temperature</b>		
<ul style="list-style-type: none"> <li>Integral type</li> </ul>	-10 °C - +80°C (14°F - 176°F)	
<ul style="list-style-type: none"> <li>Remote type</li> </ul>	Neoprene & Polyurethane Liner -10 °C - +80°C (14°F - 176°F)	PTFE Liner -10 °C - +150°C (14°F - 302°F)
<b>Ambient Temperature</b>	-10 °C - +60°C (-14°F - 140°F)	
<b>Ambient Humidity</b>	5 ~ 90% RH (relative humidity)	
<b>Medium Electrical Conductivity</b>	≥ 5 us/cm	
<b>Measuring Range</b>	1200 : 1, flow rate ≤ 12 m/s (39 ft/s)	
<b>Power Supply</b>	85VAC-250VAC; 20VDC-36VDC Dissipation Power: < 20W	
<b>Structure Type</b>	Integral type, remote type, submersible type	

Figure 1.6 MAG888 Specifications

## 2. Installation and Measurement

### §2.1 Unpacking

Please unpack the shipping box and check the parts and documents against the packing slip. If there is anything missing, the device is damaged, or something is abnormal, please contact us immediately and do not proceed with the installation.

**WARNING!**

**The MAG888 can be used to measure the flow of many kinds of liquids. Some of the liquids may be hazardous. It is very important that you comply with local safety codes and regulations in installing and using electronic devices in your area.**

### §2.2 Installation Considerations

This section provides guidelines for installing the MAG888.

#### §2.2.1 Installing the Unit

The MAG888's electronics are inclosed in a weather-resistant and dust-tight enclosure. Therefore, the main unit can be installed indoors and outdoors. Usually, it is mounted in a meter shed or on a location where one can easily access for meter testing and servicing. The main unit should be installed in an area that it is not exposed to continuous saturation or relative humidity of greater than 90%.

#### §2.2.2 Installing the Flowcell

The flowcell should be installed by or under the supervision of a professional. When installing the MAG888 in an environment involving hazardous liquids please follow proper safety protocol. Please refer to Appendix E for installation recommendations

## §2.3 Wiring

### WARNING!

**Be careful about the power supply type of your flowmeter and the power supply wiring! Connecting to a wrong type power source or improper connection of line power could damage the flowmeter. It may also cause hazardous voltage at enclosure, flow cell, and associated piping.**

**Never install the flowmeter or do the wiring with power supply on!**

Your MAG888 will require a power supply of either 85VAC-250VAC; 20VDC-36VDC. Opening the flowmeter enclosure you should see seven terminal blocks. Refer to Figure 2.2 Terminal Connectors for details regarding these terminals.

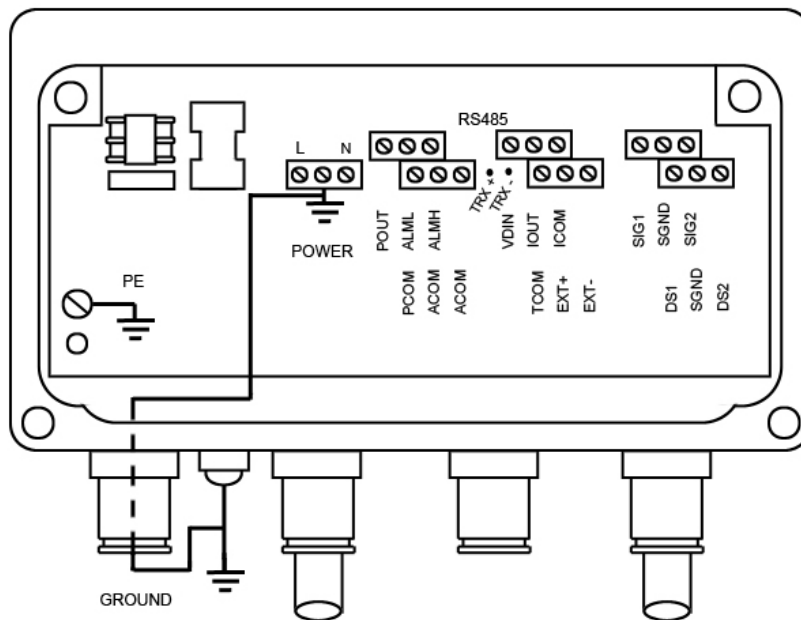

Figure 2.2 Terminal Connectors for Rectangle Model (Remote Type)

SIG 1	Signal 1	} ——— To Separate Model Sensor
SGND	Signal Ground	
SIG 2	Signal 2	
DS1	Shielded Exciting 1	
DS2	Shielded Exciting 2	
EXT +	Exciting Current +	
EXT -	Exciting Current -	
VDIN	Current Two lines 24 V Spots	} ——— Analog Current Output
ICOUT	Analog Current Output	
ICCOM	Analog Current Output Ground	
POUT	Flow Frequency ( Pulse ) Output	} ——— Frequency ( Pulse ) Output
PCOM	Frequency ( Pulse ) Output Ground	
ALMH	Upper Limit Alarm Output	} ——— Two Alarm Outputs
ALML	Low Limit Alarm Output	
ALCOM	Alarm Output Ground	
TRX +	Communication Input (RS485-A)	} ——— Communication Input
TRX -	Communication Input (RS485-B)	
TCOM	232 Communication Ground	

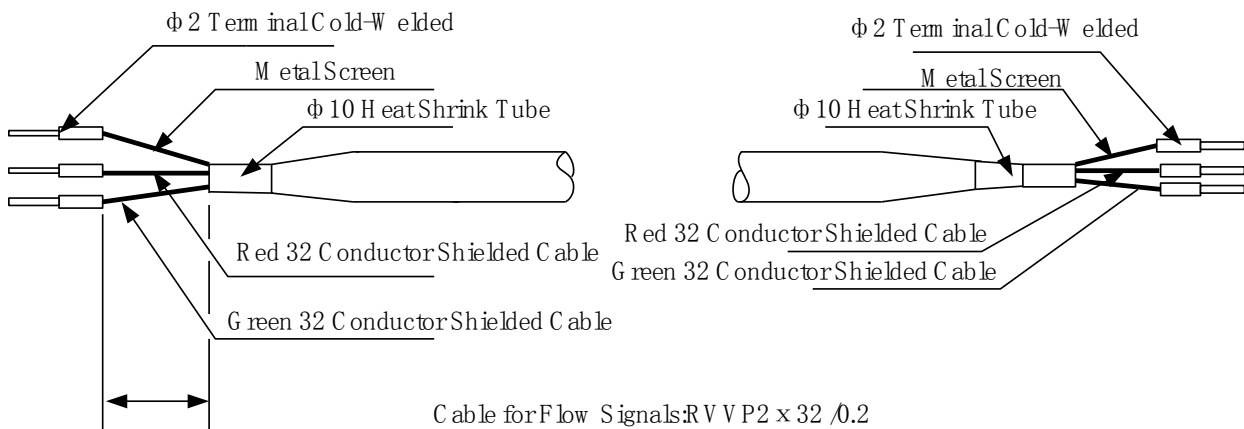

Figure 2.3 Connection and labels of signal lines in rectangle model (remote type)

Note:

For grounding wiring, please see Appendix D.

For HART, PROFIBUS, BACnet, LonWorks, Wireless or other communication interface, please consult Spire Metering at [support@spiremt.com](mailto:support@spiremt.com).

§2.3.1 Terminals and labels of connectors in Circular Model (integral type flowmeter)

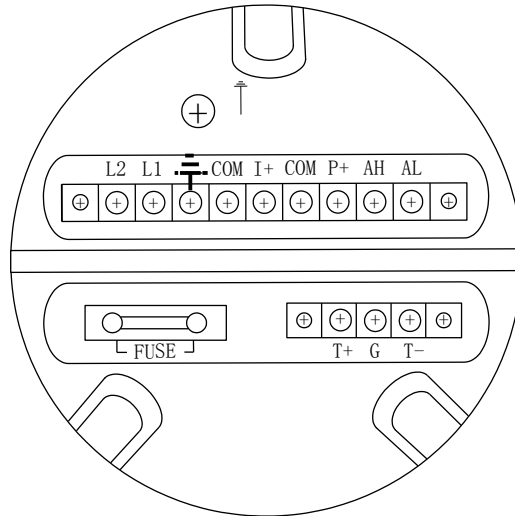

Figure 2.4 Connectors for circular model

Symbols and Description of Connectors in Circular Pane

I+:	Output Current for Flow Measurement
COM:	Output Current (Ground) for Flow Measurement
P+:	Frequency(Pulse) Output for Bi-directional Flow
COM:	Frequency (Pulse) Output (Ground)
AL:	Alarm Output for Low Limit
AH:	Alarm Output for Upper Limit
COM:	Alarm Output (Ground)
FUSE:	Fuse for Power Supply
T+:	+Communication Input Signal(RS485-A)
T-:	-Communication Input Signal(RS485-B)
G	RS232 Communication Ground
L <sub>1</sub> :	220V (24V) Power Supply
L <sub>2</sub> :	220V (24V) Power Supply

### §2.3.2 Labels and connection of signal lines in circular model

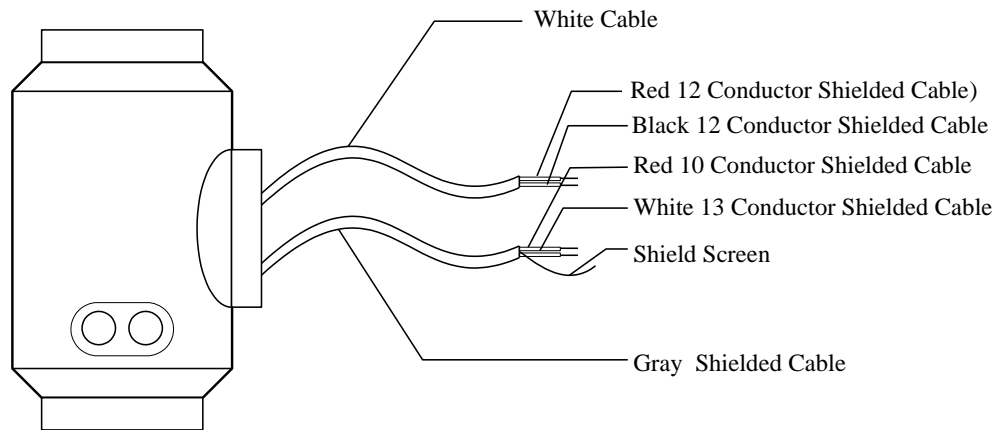

Figure 2.5 Labels and connection of signal lines in circular model

Signal lines labels in circular model:

White twisted-pair cable (for exciting current): 12 Conductors (Red)

12 Conductors (Black)

Gray shielded twisted-pair cable: 10 Conductors (Red) connected to “Signals 1”

13 Conductors (White) connected to “Signals 2”

Shielded Conductor connected to “Signal Ground”

### §2.3.3 Characteristic and connection of cable

#### §2.3.3(a) Flux signal line

When separated models of converters are assembled with sensors for measuring flow of fluid which conductivity is larger than  $50\mu\text{S}/\text{cm}$ , PVVP  $2*0.2\text{ mm}^2$  model cable ( metal shielded signal cable covered with PVC) can be used as communication cable for flow signals. The length of signal cable should be less than 100 m. Signal cables have to be connected to sensors that were assembled by producers. Connections of signal cables are shown in Figure 2.3 for squire-shaped models and Figure 2.5 for circle-shaped models, respectively.

The converter can output equivalent level of shielded exciting signal voltage so that interference to flow measurement signals can be reduced by means of lowering the distributed capacitance of communication cable. When measured conductivity is less than  $50\mu\text{S}/\text{cm}$  or signals



are transferred in remote distances, double-conductor and double-shielded signal cable at equivalent level of voltage can be used. For example, special STT3200 cable or BTS model signal cable (triple-shielded) can be used for signal communication.

### §2.3.3(b) Exciting current cable

Two conductor and insulating rubber- covered cables can be used as exciting current cables. Suggested model is RVVP2\*0.3mm<sup>2</sup>. Length of exciting current cable should be equal to that of signal cable. When the model STT3200 cables are used for exciting current and signals, two cables can be put together as one cable.

### §2.3.3(c) Output and power line

All cables for signal transferring and power supply have to be prepared by users. However, you should be careful to choose the cables that meet the upper limit load of consuming current.

Note: When the DIP switch next to terminal is set to ON places, the converter from its inside can provide +28V power supply and up-pull 10kΩ resistance to output Frequencies (PUL) to isolated OC gate, Alarm Output (ALMH.ALML), and Status Control (INSW). Therefore, when converter has frequency output and works with sensor together, DIP switch can be set as ON getting frequency signals from POUT and PCOM terminals.

Pulse current output, alarm current output and external power supply can be seen in Figure 2.6(a). When inductive load is connected to converter, diode should be used as in Figure 2.6(b).

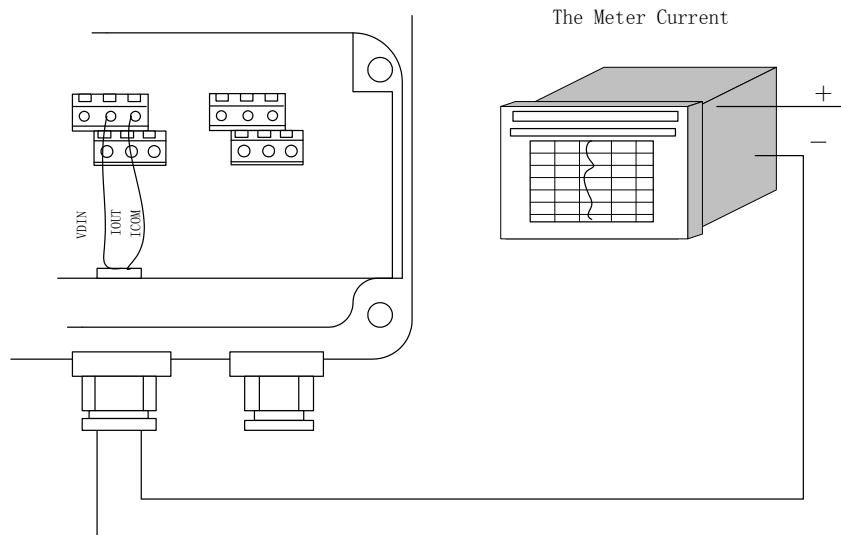

Figure 2.6(a) Output current circuit

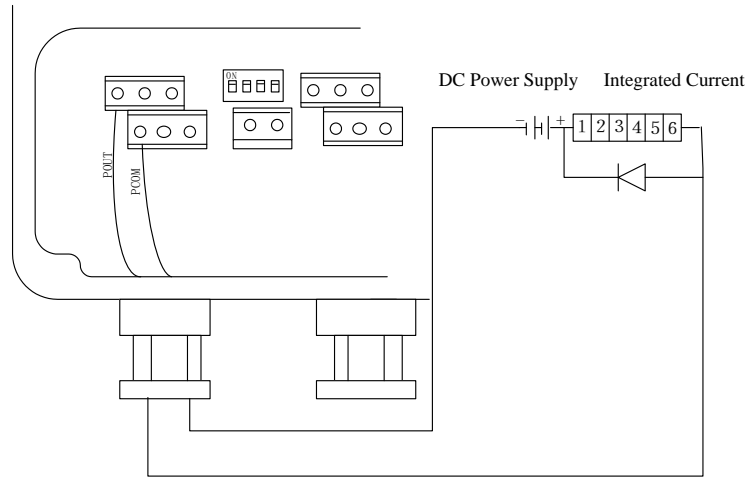

Figure 2.6(b) Connection of electro-magnet counter

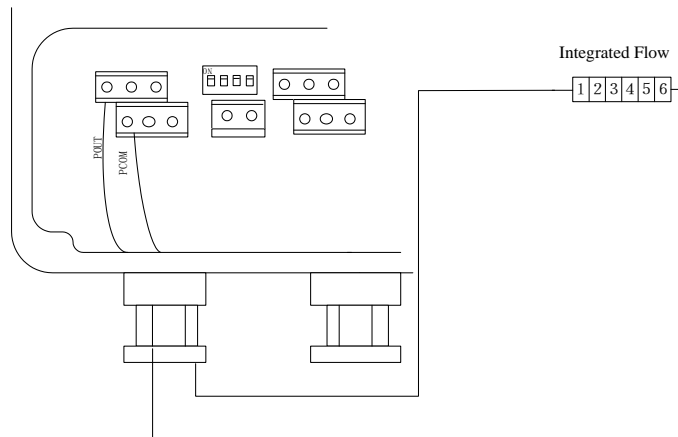

Figure 2.6(c) Connection of electronic counter

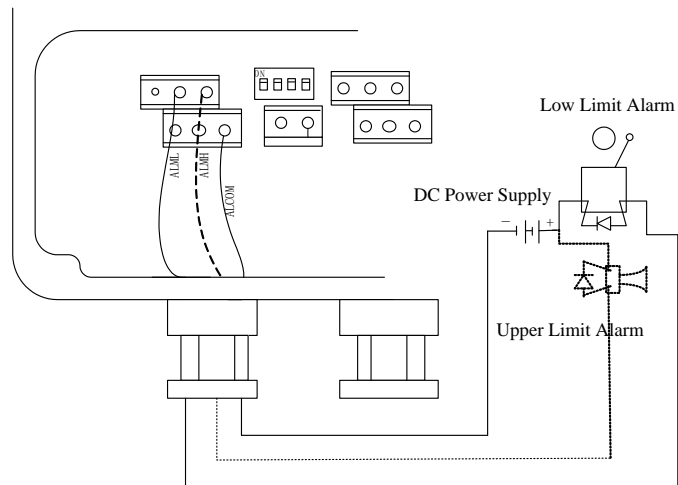

Figure 2.6(d) Connection of alarm output

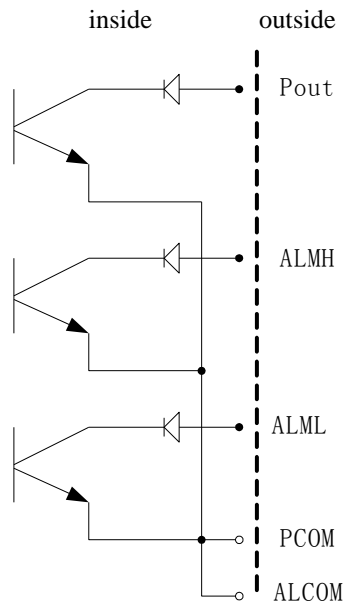

Figure 2.6(e) Connection of OC gate

### §2.3.3(d) Grounding

**Please note that grounding is very important for guarantee the measurement accuracy as well as for safety protection.** The contact area of copper Connector PE on Converter Cabinet for grounding should be larger than  $1.6\text{mm}^2$ . Contact resistance should be less than  $10\Omega$ .

Please see Appendix D for earth grounding recommendations.

### §2.3.4 Digital output and calculate

Digital output means frequency output and pulse output, and both of them use the same output point, so user can choose only one type of them but not both.

#### §2.3.4(a) Frequency output

Frequency output range is  $0\sim 5000\text{HZ}$ , and corresponds to the percent of flux.

$$F = \frac{\text{Measure value}}{\text{Full scale value}} \bullet \text{ frequency range}$$

The up limit of frequency output can be adjusted. It can be chosen from  $0 \sim 5000\text{HZ}$ , and also can be chosen low frequency: such as  $0 \sim 1000\text{HZ}$  or  $0 \sim 5000\text{HZ}$ .

Frequency output mode general can be used in control application, because it responds the percent flux. Users can choose pulse output when the equipment is applied to count.

**§2.3.4(b) Pulse output mode:**

Pulse output mainly applies in count mode. A pulse output delegates a unit flux, such as 1L or 1M<sup>3</sup> etc. Pulse output unit divide into 0.001L, 0.01L, 0.1L, 1L, 0.001M<sup>3</sup>, 0.01M<sup>3</sup>, 0.1M<sup>3</sup>, 1 M<sup>3</sup>. When users choose the pulse unit, they should notice the match of the flux range of flowmeter and pulse unit. For volume flux, count formula as follows:

$$Q_L=0.0007854 \times D^2 \times V \text{ (L/S)}$$

$$\text{Or } Q_M=0.0007854 \times D^2 \times V \times 10^{-3} \text{ (M}^3\text{/S)}$$

Note: D-nozzle (mm)

V-velocity of flow (m/s)

The oversize flux and too small pulse unit will be made the pulse output over the up limit. Generally, pulse output should be controlled below 3000P/S. However, the too small flux and too large pulse unit will be made the instrument exports a pulse long time.

Otherwise, pulse output is different from frequency output. When pulse output cumulates a pulse unit, it exports a pulse. Therefore, pulse output is not equality. Generally, measure pulse output should choose to count instrument, but not frequent instrument.

**§2.3.4(c) The connection of digital output**

Digital output has tow connected points: digital output connected point, digital ground point, and symbol as follows:

POUT ----- digital output point;

PCOM ----- digital ground point;

POUT is collector plough output, user may refer to next circuit to connect.

§2.3.4(d) The connection of digital voltage output

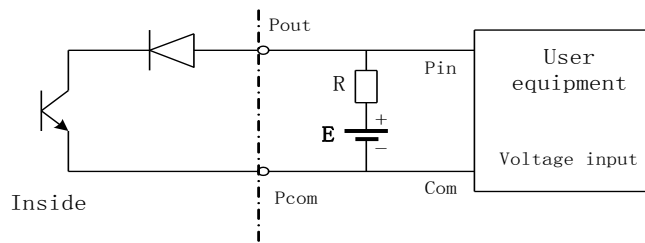

Figure 2.7(a) The connection of digital voltage output

§2.3.4(e) Digital output connect photoelectrical coupling (PLC etc.)

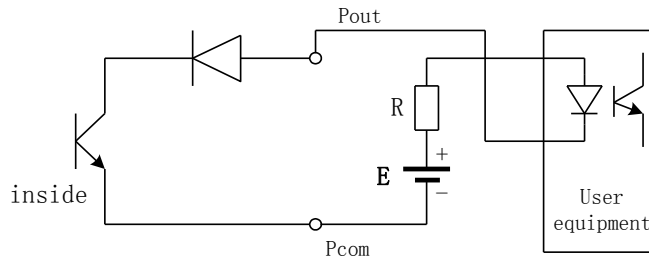

Figure 2.7(b) Digital output connect photoelectrical coupling

Commonly user's photoelectrical coupling current is about 10mA, so about  $E/R=10\text{mA}$ ,  $E=5\sim 24\text{V}$ .

§2.3.4(f) Digital output connect relay

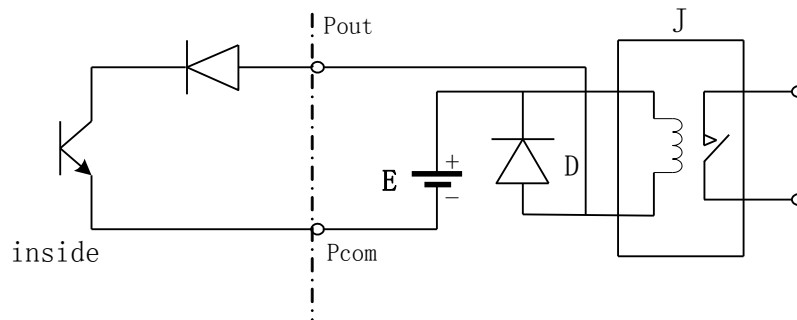

Figure 2.7(c) Digital output connect relay

Commonly relay needs E as 12V or 24V. D is extended diode, now most middle relays has this diode inside. If not have, user can connect one outside.

Table of digital output parameter:

POUT					
Parameter	Test condition	Mini	Typical	Max	Unit
Volatge	IC=100 mA	3	24	36	V
Current	Vol≤1.4V	0	300	350	mA
Frequency	IC=100mA Vcc=24V	0	5000	7500	HZ
High voltage	IC=100mA	Vcc	Vcc	Vcc	V
Low voltage	IC=100mA	0.9	1.0	1.4	V

### §2.3.5 Simulation signal output and calculate

#### §2.3.5a Simulation signal output

There are two signal system: 0~10mA and 4~20mA, user can select from parameter setting.

Simulation signal output inner is 24V under 0~20mA, it can drive 750Ω resistance.

The percent flux of simulation signal output:

$$I_0 = \frac{\text{Measure value}}{\text{Full scale value}} \bullet \text{the scale of current} + \text{the zero point of current}$$

The current zero is 0 when 0~10mA, and the current zero is 4mA when 4~20mA.

It can be advanced simulation signal output distinguish. User can select the range of measure.

The manufacture's parameter has been adjusted, it does not need adjustment. If there is abnormality, please consult section §4.6.2.

#### §2.3.5b Simulation Signal Output Adjust

##### (1)The Converter adjust preparative

When the converter is running 15 minutes, the inner of converter becomes stabilization. Preparative 0.1% ampere meter or 250Ω、 0.1% voltage instrument.

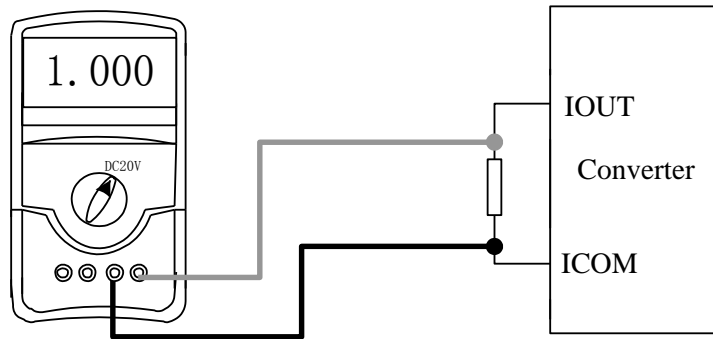

(2)Current zero correct

When the converter getting into parameter setting, selecting to “Analog Zero” and enter to it. The standard of signal fountain getting to “0”.Adjust parameter make ampere meter is 4mA(±0.004mA).

(3)The full scale current correct

To select “Anlg Range” to enter. Adjust the converter parameter make ampere meter is 20mA(±0.004mA)

Adjust the current zero and the full range, the current function of the converter reached exactness. The line degree of current output of conversion should be controlled within the scope of 0.1%

(4) Current line degree checking

You can place the standard signal source in 75%、50%、25%, and check the line degree of current output.

§2.3.5(c) MAG888 magnetic flowmeter converter’s connection of current output:

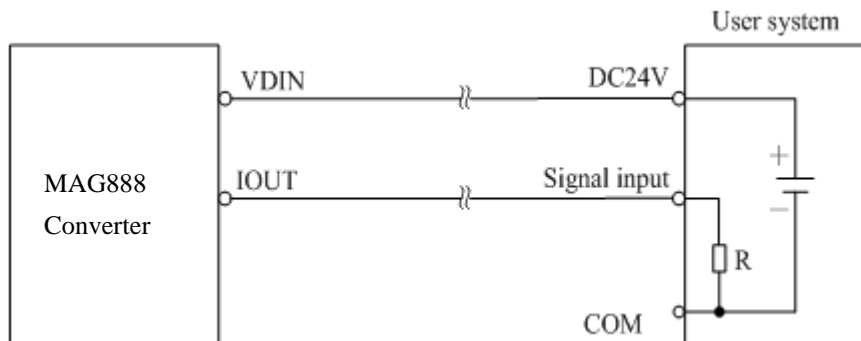

Figure 2.8(a) MAG888 Two Connection

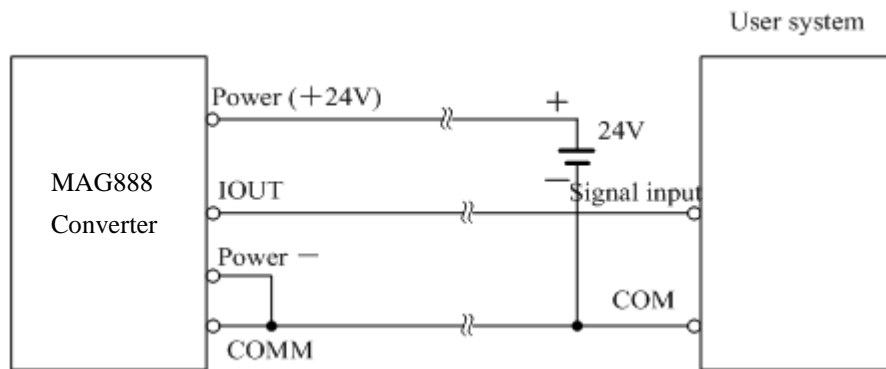

Figure 2.8(b) MAG888 three connection (power supply and current output are not insulated)

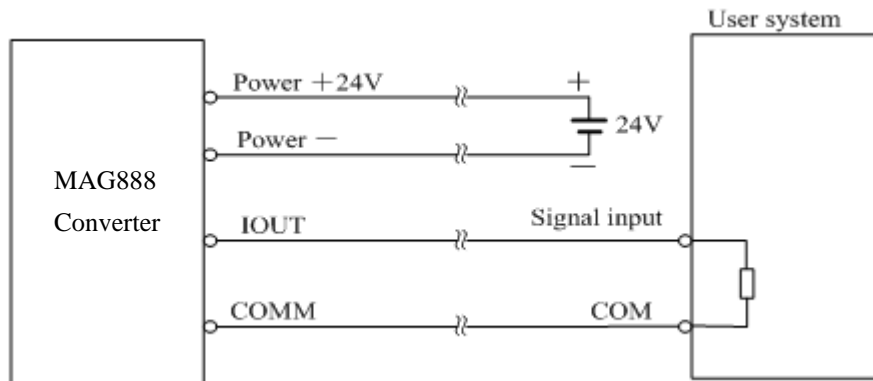

Figure 2.8(c) MAG888 four connection (power supply and current output are insulated)

### §2.3.6 Other Electrical Connections

#### *Wiring RS-485*

Refer to Figure 2.2 for terminal location. Please also see Appendix A.

#### *Wiring 0/4-20mA Output*

Using standard twisted-pair wiring. Refer Figure 2.2 for terminal location.

#### *Wiring 0/4-20mA Input*

The analog input channel can be wired to the terminal block using standard twisted-pair wiring. Please refer to Figure 2.2 for terminal location.



## §2.4 Power Up

The MAG888 does not have power ON/OFF switch. When it is connected to power, it will start to run automatically.

After the power is turned on, the flowmeter will run a self-diagnostic program, checking first the hardware and then the software integrity. If there is any abnormality, corresponding error messages will be displayed. (Contact [support@spiremt.com](mailto:support@spiremt.com) if error messages are displayed)

### **WARNING!**

**Before connecting the device to power source, please do a final check to make sure all the wirings are correct and all the local safety codes are followed.**

After successful internal checks, the MAG888 will display the flow measurement program window which displays flow velocity, volumetric summation, and other measurable flow characteristics.

The flow measurement program always operates in the background of the user interface. When the user makes changes to parameter settings, the MAG888's flow measurement window will reflect the changes instantly.

## §2.5 Keypad

The keypad of the MAG888 electromagnetic flowmeter has 4 keys that enable the user to navigate between menus, enter values, and modify parameter settings. The '4 key' layout is depicted below in Figure 2.4.

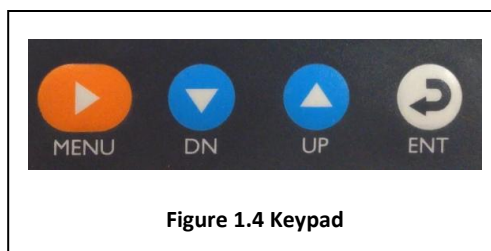

The **MENU** key alternately functions as a shift key. Holding **MENU** while pressing arrow keys allows the user to move the cursor to modify numerical values. Holding **MENU** while pressing the **ENT** key will bring you to the secondary menu where you can access Parameters, Clr Total Rec, and Fact Modif Rec. This feature is explained in detail in section 2.5 *Quick Start Menu Navigation*.

The **ENT** key is the ENTER key for any input or selections. Pressing **ENT** allows the user to enter a

selected option from a menu or numerical value. Pressing and holding **ENT** for 8 seconds from any menu screen allows the user to return to the flow measurement window (the home screen).

The **↑** and **↓** keys are used for navigation. These directional keys allow the user to navigate through the menus, change numeric values, and modify parameter settings from lists of options. When entering numbers the **↑** key is +1 and the **↓** key is -1. While holding **MENU**, the **↑** and **↓** keys move the cursor to modify numerical values for password entry and entering parameter settings.

## §2.6 Quick Start Menu Navigation

### Step 1: Power On

Upon power up of the MAG 888 you will be prompted with the flow measurement window. The flow measurement window in Figure 2.5 provides the user with real-time volume and velocity readings as well as a programmable alarm indicator and flow units.

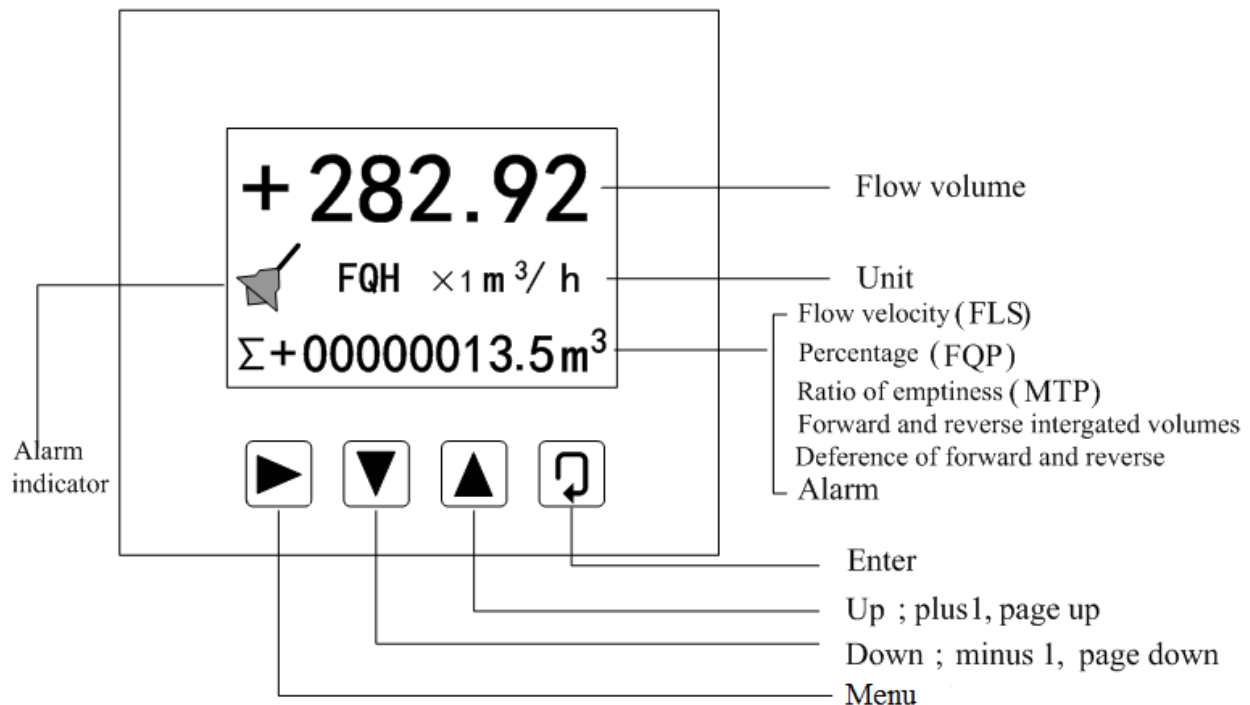

Figure 2.5 Flow Measurement Window

**Step 2: Configure the Flowmeter**

The MAG888 can be configured in the Parameter Settings menu. To access the parameter settings menu, from the flow measurement window, simultaneously press **MENU** + **ENT**. When the screen reads “Parameters Set,” press **ENT**. You will be prompted to enter a five-character password. Holding **MENU**, press **↑** to move the cursor one character to the right. Use the **↑** and **↓** keys to change the value. The password to modify all Parameter Settings is **07206**. When the password is entered press **MENU** + **ENT** (Note: if the password does not work refer to §3.1 for alternate passwords). For a complete table of the Parameter Settings and passwords see §3.1 Parameter Settings Configuration and Access Passwords. Navigate through the parameter settings using the **↑** and **↓** keys. For parameter details refer to §3.3 Parameter Details. To return back to the flow measurement window hold **ENT** for 8 seconds.

### 3. Menu Windows & Details

#### §3.1 Parameter Settings Configuration and Access Passwords

The MAG888 has 5 different levels of passwords which allow access to different menu windows and the ability to change their parameter settings. To enter the password, from the main screen, press the **MENU** and **ENT** buttons simultaneously. For access to all menus enter the factory set password **07206**, otherwise,

Level 1 password (set by manufacturer as **00521**): Allows users read-only privileges of parameter settings.

Level 2 password (set by manufacturer as **03210**): Allows users to change parameter settings menus 1 ~ 24.

Level 3 password (set by manufacturer as **06108**): Allows users to change parameter settings menus 1 ~ 25.

Level 4 password (set by manufacturer as **07206**): Allows users to change parameter settings menus 1 ~ 38.

Level 5 password (Fixed): Allows users to change parameter settings menus 1 ~ 52.

**Note:** Alternate versions of the MAG888 may require the following passwords: **19818**, or **1111**

#### §3.2 Table of Parameter Setting Menu

Item No.	Menu Display	Setting Method	Value Range	Password Level
1	Language	Option	English	2
2	CommAddress	User set	0 ~ 99	2
3	Baud Rate	Option	600 ~ 14400	2
4	Snsr Size	Option	3 ~ 3000	2
5	Flow Unit	Option	<i>L/h, L/m, L/s, m<sup>3</sup>/h, m<sup>3</sup>/m, m<sup>3</sup>/s, UKG, USG</i>	2
6	Flow Range	Modify	0 ~ 99999	2
7	Flow Rspns	Modify	1 ~ 50	2
8	Flow Direct	Option	Plus/ Reverse	2
9	Flow Zero	Modify	0 ~ ± 9999	2
10	Flow Cutoff	Modify	0 ~ 599.99%	2
11	Cutoff Ena	Option	Enable/ Disable	2
12	Total Unit	Option	0.001m <sup>3</sup> ~ 1m <sup>3</sup> , 0.001L ~ 1L, 0.001UKG ~ 1UKG 0.001USG ~ 1USG	2
13	SegmaN Ena	Option	Enable/ Disable	2
14	Analog Type	Option	0 ~ 10mA/ 4 ~ 20mA	2
15	Pulse Type	Option	Frequency/ Pulse	2
16	Pulse Fact	Option	0.001m <sup>3</sup> ~ 1m <sup>3</sup> , 0.001L ~ 1L, 0.001UKG ~ 1UKG 0.001USG ~ 1USG	2
17	Freque Max	Modify	1 ~ 5999Hz	2

MAG888 Electromagnetic Flowmeter

18	Mtsnsr Ena	Option	Enable/ Disable	2
19	Mtsnsr Trip	Modify	59999%	2
20	Alm Hi Ena	Option	Enable/ Disable	2
21	Alm Hi Val	Modify	000.0 ~ 599.99%	2
22	Alm Lo Ena	Option	Enable/Disable	2
23	Alm Lo Val	Modify	000.0 ~ 599.99%	2
24	Sys Alm Ena	Option	Enable/ Disable	2
25	Clr Sum Key	Modify	0 ~ 99999	3
26	Snsr Code1	Option	Finished Y/M	4
27	Snsr Code 2	User Set	Product No.	4
28	Field Type	Option	Type 1,2,3	4
29	Sensor Fact	Modify	0.0000 ~ 5.9999	4
30	Line CRC Ena	Option	Enable/ Disable	4
31	Lineary CRC1	User Defined	Set Velocity	4
32	Lineary Fact 1	User Defined	0.0000 ~ 1.9999	4
33	Lineary CRC2	User Defined	Set Velocity	4
34	Lineary Fact 2	User Defined	0.0000 ~ 1.9999	4
35	Lineary CRC3	User Defined	Set Velocity	4
36	Lineary Fact 3	User Defined	0.0000 ~ 1.9999	4
37	Lineary CRC4	User Defined	Set Velocity	4
38	Lineary Fact 4	User Defined	0.0000 ~ 1.9999	4
39	FwdTotal Lo	Modify	00000 ~ 99999	5
40	FwdTotal Hi	Modify	00000 ~ 9999	5
41	RevTotal Lo	Modify	00000 ~ 99999	5
42	RevTotal Hi	Modify	00000 ~ 9999	5
43	PlsntLmtEna	Option	Enable/ Disable	5
44	PlsntLmtVal	Modify	0.010 ~ 0.800m/s	5
45	Plsnt Delay	Modify	400 ~ 2500ms	5
46	Password 1	User Modify and Record	00000 ~ 99999	5
47	Password 2	User Modify and Record	00000 ~ 99999	5
48	Password 3	User Modify and Record	00000 ~ 99999	5
49	Password 4	User Modify and Record	00000 ~ 99999	5
50	Analog Zero	Modify	0.0000 ~ 1.9999	5
51	Anlg Range	Modify	0.0000 ~ 3.9999	5
52	Meter Fact	Modify	0.0000 ~ 5.9999	5
53	MeterCode 1	Factory Set	Finished Y/M	6
54	MeterCode 2	Factory Set	Product Serial No.	6

---

## §3.3 Parameter Details

### 3.3.1 Language

Language for the MAG888 can be set according to the user's needs.

### 3.3.2 Comm Address

The Comm Address is the instrument's Modbus address that is used to when communicating with many other devices (Appendix A). The user can set the Comm Address from 01~99.

### 3.4.3 Baud Rate

The Baud Rate is the number of signaling events made per second in the digitally modulated signal. Most commonly 2400, the user can select: 300, 1200, 2400, 4800, 9600, 19200, baud rate. Please refer to Appendix A for Modbus protocol

### 3.3.4 Snsr Size

The MAG888 converters can be equipped with different sensors for different diameters of measuring pipes. The pipes diameters can range from 3mm to 3000mm.

### 3.3.5 Flow unit

This parameter setting allows the user to change the flow rate unit (L/s, L/m, L/h, m<sup>3</sup>/s, m<sup>3</sup>/m, m<sup>3</sup>/h).

### 3.3.6 Flow Range

Flow range refers to the upper range value of the flow rate. The upper range value is relative to the flow percentage and output signal. At the analog output, measured values are in the range between 0 and the upper range value and is displayed linear to the current range 4-20mA. At the frequency output, measured values are in the frequency range between 0 and the upper threshold. The low flow cutoff and flow limit alarms relate to the flow range as well. The maximum measureable flow rate, however, is not limited to the flow range as long as the flow speed does not exceed 15m/s. In this menu, the user can also choose the unit of the flow rate. For volume flow, L/s, L/min, L/h, m<sup>3</sup>/s, m<sup>3</sup>/min and m<sup>3</sup>/h are available, while for mass flow, kg/s, kg/m, kg/h, t/s, t/m, t/h can be selected from. The units chosen depend on the measurement application.

### 3.3.7 Flow Rspns

Flow response is the time of the 'filter measure value'. A longer flow response can enhance the stability of flow display and output signal.

### 3.3.8 Flow Direct

If the flow rate is reading negative, change the flow direction in this parameter.

---

### 3.3.9 Flow zero

Flow zero allows the user to calibrate their meter to zero. If there is no flow in the pipe and the meter still reads a flow rate, this can be adjusted in this parameter setting. Flow zero is shown as velocity of flow in mm/s. The converter's zero-flow correction displays:

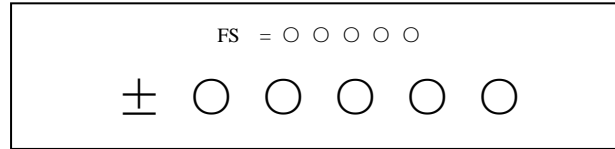

Where FS is the measured value; the lower value is the correction value of zero.

If FS does not read “0”, make FS = 0 by changing the ‘correction value’. Example: If FS = 1234, make the correction value -1234.

### 3.3.10 Flow cutoff

Flow cutoff is used to delete negligible small signals of flow volume. Set the flow cutoff slightly above the maximum reading during zero flow.

### 3.3.11 Cutoff Ena

If Cutoff is enabled and flow is lower than the set value, the display of flowrate, speed and percentage and signal outputs are forced to zero. If Cutoff is disabled, no action is taken.

### 3.3.12 Total Unit

The converter has three 10-digit counters. The counter can go to 9999999999. The total flow unit can be L, m<sup>3</sup>, kg or t (metric ton) with a multiplying factor of 0.001, 0.01, 0.1, 1, 10, 100, 1000.

### 3.3.13 SegmaN Ena

When “SegmaN Ena” is “enabled”, if there is flow, the sensor will export a pulse and current. When it is “disabled”, the sensor will export a pulse as “0” and current as “0” (4mA or 0mA) for flow reversals.

### 3.3.14 Analog Type

Output current types can be chosen by users to be 1~10mA or 4~20mA.

### 3.3.15 Pulse Type

Two kinds of Pulse Outputs can be chosen: Frequency Output and Pulse Output. The meter outputs a continuous square wave pulse in frequency mode and a pulse series in pulse mode. Frequency output is usually used for flow rate measurement and short periods of time totalizing. Pulse output can be connected to an external counter directly and is often used for long periods of time totalizing. The transistor open collector circuit is used for frequency

---

pulse output. Therefore, the external DC power supply and load are necessary.

### 3.3.16 Pulse Fact

Pulse factor is defined as: volume or mass per pulse. It can be set to 0.001L/p, 0.01L/p, 0.1L/p, 1L/p, 2L/p, 5L/p, 10L/p, 100L/p, 1m<sup>3</sup>/p, 10m<sup>3</sup>/p, 100m<sup>3</sup>/p, or 1000m<sup>3</sup>/p. Pulse width is selectable from auto, 10ms, 20ms, 50ms, 100ms, 150ms, 200ms, 250ms, 300ms, 350ms and 400ms.

### 3.3.17 Freque Max

Frequency range corresponds to the upper range value of the flow rate. The maximum frequency range is 100% of the flow rate and is selectable from 1 – 5999Hz

### 3.3.18 Mtsnsr Ena

The state of empty pipe can be detected with this function of the converter. In the case of an Empty Pipe Alarm, if the pipe was empty, the signals of the analog output and digital output would be zero. The displayed flow would also be zero.

### 3.3.19 Mtsnsr Trip

Mrsnsr is used to set the empty pipe threshold.

### 3.3.20 Alm Hi Ena

For the upper limit alarm, users can choose “Enable” or “Disable.”

### 3.3.21 Alm Hi Val

The parameter of the upper limit alarm is percentage of flow range and can be set in the way of setting one numerical value between 0%~199.9%.When the value of flow percentage is larger than the value of setting value, the converter outputs the alarm signal.

### 3. 4.22 Alm Lo Ena

For the lower limit alarm, users can choose “Enable” or “Disable.”

### 3. 4.23 Alm Lo Val

The same principle applied for Alm Hi Val in section 3.3.21.

### 3.3.24 Sys Alm Ena

For the system alarm, users can choose “Enable” or “Disable.”

### 3.3.25 Clr Sum Key

The ‘Totalizer Reset Password’ is changeable in this menu item if the level 3 password is entered. Reminder: Keep the new password in a safe place.



---

### 3.3.26 Snsr Code 1 & 2

These codes refer to the date the sensor was produced and the serial number of the product.

### 3.3.27 Field Type

The MAG888 supports three exciting frequency types: 1/16 frequency (Type 1), 1/20 frequency (Type 2), 1/25 frequency (Type 3). When using, please select Type 1 first, if the zero of velocity is too high, select the type 2 or type 3. Note: This setting should NOT be adjusted.

### 3.3.28 Sensor Fact

The sensor factor is set according to the calibration sheet supplied by the manufacturer. Usually this factor has been set up by the manufacturer before shipping. It is an important value that determines the accuracy of measurement. Do not change it without calibration.

### 3.3.29 Line CRC Ena

Factory preset, should NOT be changed.

### 3.3.30 Lineary Fact 1-4

Factory preset, should NOT be changed.

### 3.3.31 Lineary CRC 1-4

Factory preset, should NOT be changed.

### 3.3.32 FwdTotal & RevTotal (Lo & Hi)

Presetting of forward and reverse total counter is designed to start counting from the existing reading when replacing a converter or flowmeter. It provides a continuous total flow reading which is convenient for management.

### 3.3.33 PlsntLmtEn

For paper pulp, slurry and other heterogeneous flow, the flow measurement may read "cuspidal disturb," because of solid grain friction or impact of slurry on the measuring electrodes. The MAG888 converters use variation-restrain arithmetic sequence to overcome these disturbances. Setting this to "enable" will start the arithmetic sequence; setting it to "disable" will end the sequence.

### 3.3.34 PlsntLmtVal

This coefficient can disturb the variation of cuspidal disturb, and calculate as percent of flow velocity, thus ten grades: 0.010m/s, 0.020m/s, 0.030m/s, 0.050m/s, 0.080m/s, 0.100m/s, 0.200m/s, 0.300m/s, 0.500m/s, 0.800m/s, and the smaller percent, the higher delicacy of cuspidal restrain.

Note: when using it, must test for select by the fact, and sometimes it is not the higher delicacy is good.

---

### 3.3.35 Plsnt Delay

This coefficient is used to select the length time of the ‘restrain cuspidal disturb’ and the unit is ms. If the duration is too short, The MAG888 will think that it is ‘cuspidal disturb’. If it is too long, the MAG888 . It also needs to select parameter in fact.

### 3.3.36 User’s password 1~4

Users can use 5 levels of passwords to correct these passwords. Reminder: Keep passwords in a safe place.

### 3.3.37 Analog Zero

The analog output is zero calibrated by the factory and adjustments should NOT be made by the user.

### 3.3.38 Anlg Range

Here you can adjust the analog output range (units are in mA).

The 4mA corresponding flow is automatically set to 0  $m^3/h$ . The 20mA corresponding flow is 100  $m^3/h$ , to change it follow these steps:

- Press ‘Menu’ + ‘Enter’ key, it displays ‘Parameters Set’ function.
- Input password.
- Press ‘Menu’ + ‘Enter’ key, it getting to Parameters Setting status.
- Scroll up to ‘flow range then’ enter
- Change the value corresponding to 20mA

Note: 1  $m^3/h = 4.403 GPM$

### 3.3.39 Meter Fact

This is the meter factor which is the factor used by the manufacturer to normalize the excitation current and amplifier signal of the converter. DO NOT change it.

### 3.3.40 MeterCode 1 & 2

Converter code records the date of manufacturing and serial number of converter.

---

## 4. Warranty and Services

### §4.1 Warranty

The products manufactured by Spire Metering are warranted to be free from defects in materials and workmanship for a period of one year from the date of shipment to the original purchaser. Spire Metering's obligation should be limited to restoring the meter to normal operation or replacing the meter, at Spire Metering's choice, and shall be conditioned upon receiving written notice of any alleged defect within 10 days after its discovery. Spire Metering will determine if the return of the meter is necessary. If it is, the user should be responsible for the one-way shipping fee from the customer to the manufacturer.

Spire Metering is not liable to any defects or damage attributable to misuse, improper installation, out-of-spec operating conditions, replacement of unauthorized parts and acts of nature. Besides, fuses and batteries are not part of this warranty.

THE FOREGOING WARRANTY IS EXCLUSIVE AND IN LIEU OF ALL OTHER EXPRESS OR IMPLIED WARRANTIES (INCLUDING BUT NOT LIMITED TO WARRANTIES OF MERCHANTABILITY AND FITNESS FOR A PARTICULAR PURPOSE, AND WARRANTIES ARISING FROM DEALING, TRADE OR USAGE.)

### §4.2 Service

The manufacturer provides instrument installation for its customers, and the charge will depend on the complexity of the installation.

For operational problems, please contact the technical support department by telephone, fax, email or internet. In most cases, problems could be solved immediately.

For any hardware failure of the instrument, we recommend our customers to send back the instrument for service. Please contact the technical support department with the model number and serial number of the unit before sending the unit back to us. Both numbers can be found on the product label. For each service or calibration request, we will issue a Return Materials Authorization (RMA) number.

Take notice that the cost for repairing can only be determined after receipt and inspection of the instrument. A quotation will be sent to the customer before proceeding with the service.

### **Important Notice for Product Return**

Before returning the instrument for warranty repair or service, please read the following carefully:

1. If the return item has been exposed to nuclear or other radioactive environment, or has been in contact with hazardous material which could pose any danger to our personnel, the unit cannot be serviced.

- 
2. If the return item has been exposed to or in contact with dangerous materials, but has been certified as hazard-free device by a recognized organization, you are required to supply the certification for the service.
  3. If the return item does not have a RMA# associated, it will be sent back without any service conducted.

#### **§4.3 Software Upgrade Service**

We provide free-of-charge software upgrade services. Please contact the manufacturer for the software upgrade information.

---

## Appendixes

### Appendix A MODBUS COMMUNICATION PROTOCOL

MAG888 communication protocol uses standard MODBUS RTU communication protocol. MAG888 device is defined as the slave. It supports half-duplex communication at 1200, 2400, 4800, 9600 or 19200 baud rate.

The Master device must have a communication buffer (FIFO) for at least 11 bytes.

#### 1. RTU Message Frame Definition

Data communication is initiated by the master. First, the master transmits the RTU message frame. Messages start with a silent interval of at least 3.5 character times. The first field transmitted is the device address. The allowable characters transmitted for all fields are hexadecimal 0 ... 9, A ... F. Slave devices monitor the network bus continuously, including the silent intervals. When the first field (the address field) is received, each slave decodes the message to find out if the message is for itself. Following the last transmitted character, an interval of at least 3.5 character times long marks the end of the message. A new message can start again after this interval.

The entire message frame must be transmitted as a continuous stream. If a silent interval of more than 1.5 character times occurs before completion of the frame, the receiving device (slave) flushes the incomplete message and assumes that the next byte will be the address field of a new message. Similarly, if a new message begins earlier than 3.5 character times following a previous message, the slave will consider the new message as a continuation of the previous message. In this case, the value in the final CRC field will not be valid for the combined messages. As a result, the slave will treat this message as an invalid message.

The commands implemented in MAG888 include 03 (Read Register), 04 (Read Variable) and 06 (Write Register).

#### 2. Register Read Command

##### (1) Master Command Format

0	1	2	3	4	5	6	7
Device address (8 bit)	Function code (8 bit)	Register Address (16 bit)		Register Data (16 bit)		CRC (16 bit)	
1~99	03	0000--0035		xxxx		xxxx	

---

(2) Slave Response Format

0	1	2	3	4	5	6
Device address (8 bit)	Function code	Length (8 bit)	Data1 (High byte)	Data0 (Low byte)	CRC (16 bit)	
1~99 (8 bit)	03 (8 bit)	02	xx	xx	xx	

Data= data1 data0

### 3. Register Write Command

(1) Master Command Format

0	1	2	3	4	5	6	7
Device address (8 bit)	Function code (8 bit)	Register Address (16 bit)		Data1 (High byte)	Data0 (Low byte)	CRC (16 bit)	
1~99	06	0000--0035		xx	xx	xxxx	

(2) Slave Response Format

0	1	2	3	4	5	6	7
Device address (8 bit)	Function code (8 bit)	Register Address (16 bit)		Data1 (High byte)	Data0 (Low byte)	CRC (16 bit)	
1~99	06	0000--0035		xx	xx	xxxx	

When the slave responses, it transmits what it has just received to the master, and the master can use it for verification. Note: this data is not the data after written. The slave needs 50ms to change the register, so that you can read the register correctly 50ms later.

**Register Table I**

Register Address	Description	Notes
1000H	Flowrate (High Byte)	
1001H	Flowrate (Low Byte)	
1002H	Positive Total (High Byte)	
1003H	Positive Total (Low Byte)	
1004H	Negative Total (High Byte)	
1005H	Negative Total (Low Byte)	
1006H	Flow Velocity	Fixed format: XX. XXX m/s
1007H	Flowrate Ratio (For Battery powered Unit)	
1008H	Liquid Conductivity Ratio	Fixed format: XXXXX %
1009H	Unit for Flowrate and Total	(1)
100AH	Battery and Alarm (For Battery powered Unit)	(2)

Note:

(1) For Register 1009, Unit of Flowrate and Total, the bit definition is shown below:

1009H															
Flowrate decimal and Unit								Flow Total decimal and Unit							
Bit	Bit	Bit	Bit	Bit	Bit	Bit	Bit	Bit	Bit	Bit	Bit	Bit	Bit	Bit	Bit
15	14	13	12	11	10	9	8	7	6	5	4	3	2	1	0

Flowrate decimal and Unit:

BIT15: sign. 1- negative; 0-positive

BIT14-12: decimal point position

BIT14-12= 0 .00000

BIT14-12= 1 0.0000

BIT14-12= 2 00.000

BIT14-12= 3 000.00

BIT14-12= 4 0000.0

BIT14-12= 5 00000.

BIT10-8: Unit

BIT10-8= 0 LTR / s

BIT10-8= 1 LTR / m

BIT10-8= 2 LTR / h

BIT10-8= 3 M3 / s

BIT10-8= 4 M3 / m

BIT10-8= 5 M3 / h

Flow Total decimal and Unit:

BIT6-4: decimal point position

BIT6-4= 0 .00000

BIT6-4= 1 0.0000

BIT6-4= 2 00.000                      BIT6-4= 3 000.00  
 BIT6-4= 4 0000.0                      BIT6-4= 5 00000.

BIT2-0: Unit

BIT2-0= 0 LTR                      BIT2-0= 1 LTR  
 BIT2-0= 2 LTR                      BIT2-0= 3 M3  
 BIT2-0= 4 M3                      BIT2-0= 5 M3

(2) Battery and Alarm

100AH															
High Byte								Low Byte							
Bit	Bit	Bit	Bit	Bit	Bit	Bit	Bit	Bit	Bit	Bit	Bit	Bit	Bit	Bit	Bit
15	14	13	12	11	10	9	8	7	6	5	4	3	2	1	0

The register high byte is the battery level: 0-5

The register low byte is for alarm:

- BIT0 – weak signal alarm
- BIT 1 – empty pipe alarm
- BIT 2 – system alarm (for battery powered unit)
- BIT 3 – upper limit alarm
- BIT 4 – lower limit alarm

**Register Table II**

(For PLC)

PLC Addresses (Base 1)	Protocol Addresses (Base 0)	Data Format	Description
34113	0x1010	Float Inverse	Flowrate in float
34115	0x1012	Float Inverse	Velocity in flow
34117	0x1014	Float Inverse	Flowrate Ratio in flow (for battery powered unit)
34119	0x1016	Float Inverse	Liquid Conductivity Ratio in float
34121	0x1018	Long Inverse	Positive Totalizer – Integer portion
34123	0x101A	Float Inverse	Positive Totalizer – Decimal portion
34125	0x101C	Long Inverse	Negative Totalizer – Integer portion
34127	0x101E	Float Inverse	Negative Totalizer – Decimal portion
34129	0x1020	Unsigned short	Flowrate Unit



---

34130	0x1021	Unsigned short	Flow Totalizer Unit
34131	0x1022	Unsigned short	Upper Limit Alarm
34132	0x1023	Unsigned short	Lower Limit Alarm
34133	0x1024	Unsigned short	Empty Pipe Alarm
34134	0x1025	Unsigned short	System Alarm

---

## **Appendix B HART COMMUNICATION PROTOCOL**

Please contact [support@spiremt.com](mailto:support@spiremt.com) for the information

---

## **Appendix C PROFIBUS COMMUNICATION PROTOCOL**

Please contact [support@spiremt.com](mailto:support@spiremt.com) for the information

---

## Appendix D EARTH GROUNDING

The sensor body must be grounded using grounding or bonding straps or grounding rings to protect flow signal against stray electrical noise and lightning. Well-grounded installation will make noise carried through sensor body so that the measuring area within sensor body is noise-free.

For metal pipes:

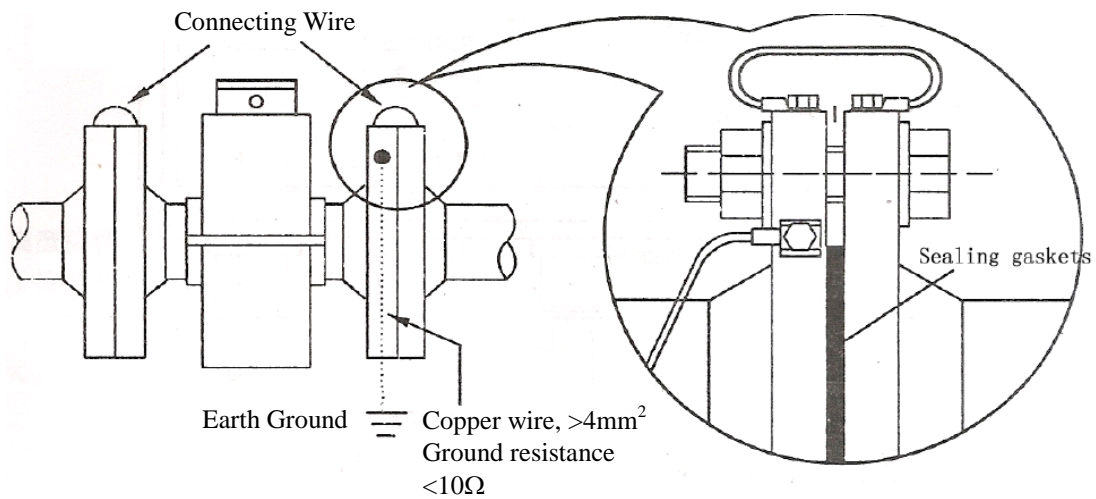

For non-metallic pipes:

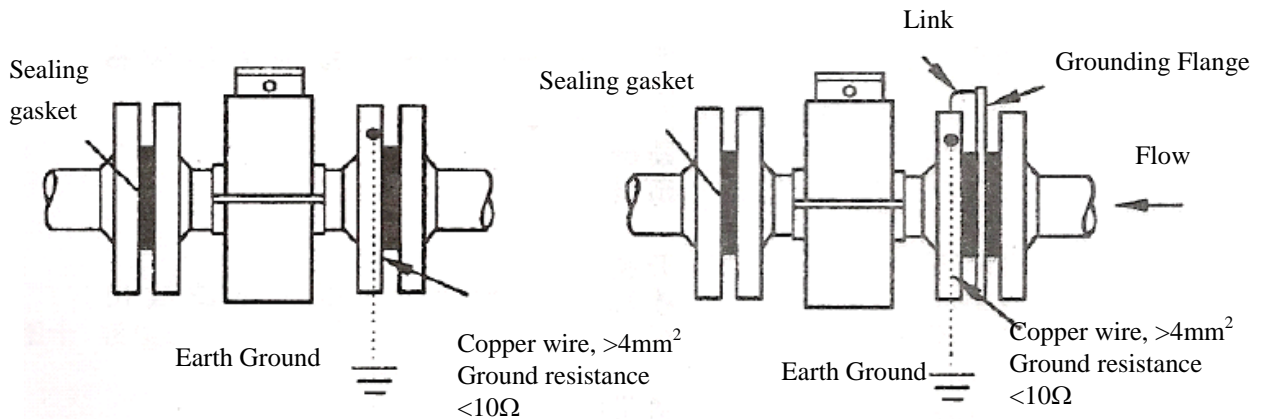

For pipe lines with cathodic protection:

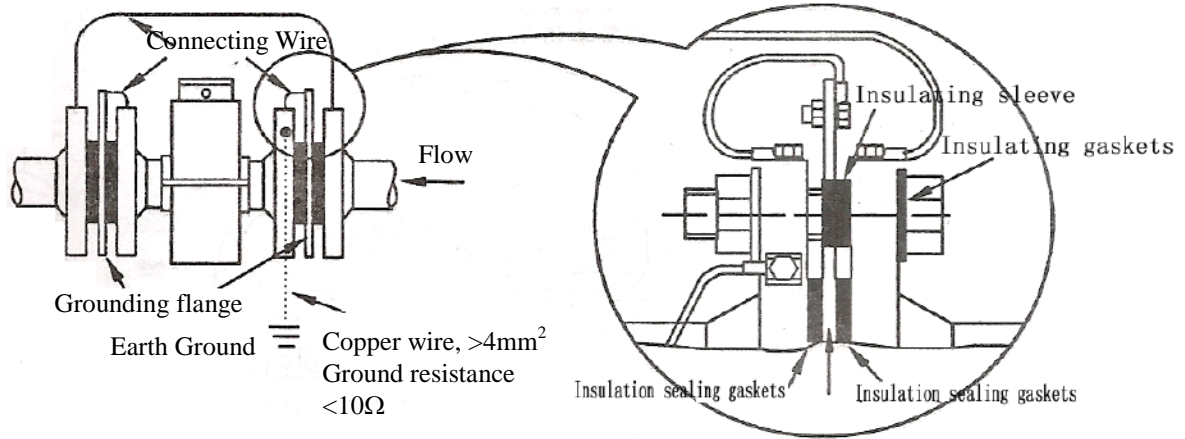

## LIGHTNING PROTECTION NOTE

When installing, you need to connect the converter's Earth terminal with the metal enclosure, and then to the earth ground reliably, because electrical current could flow from the earth ground through the metal enclosure by the gas discharger of a lightning protection device. If the enclosure has not been connected to the earth ground reliably, once lightning, it may cause a personal accident when there is somebody operating the converter. Please refer to the below drawing for wiring details.

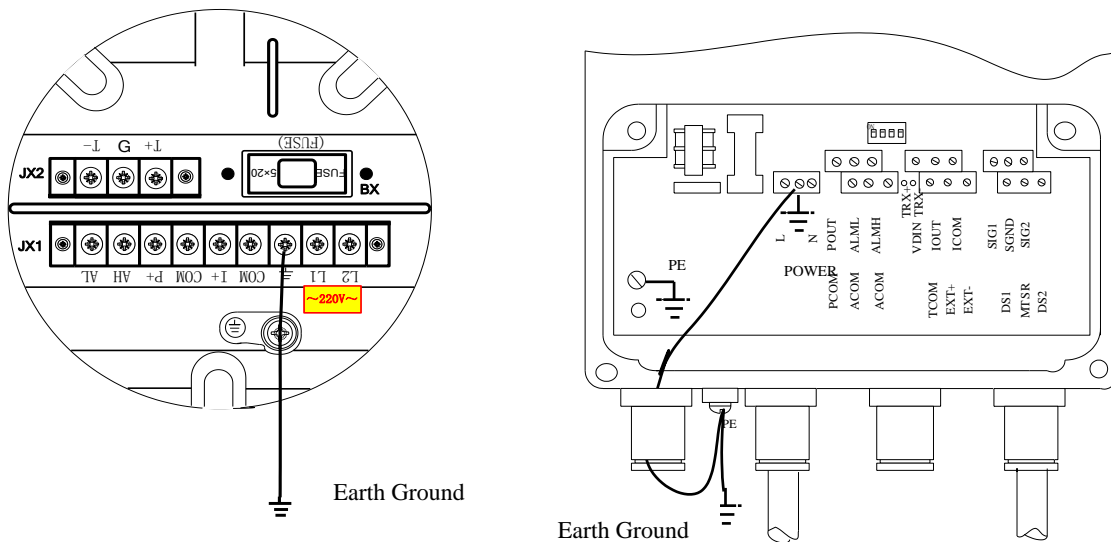

## Appendix E FLOW SENSOR INSTALLATION RECOMMENDATIONS

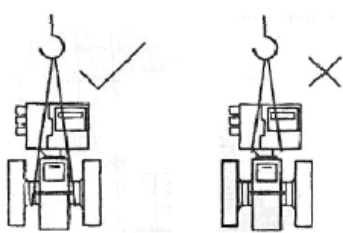
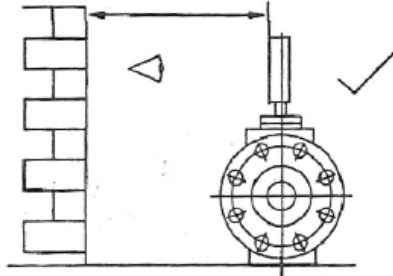
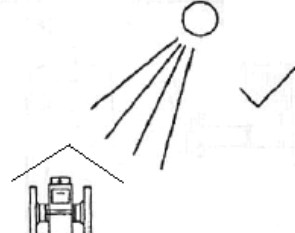
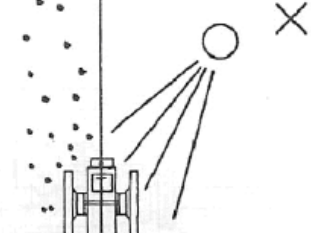
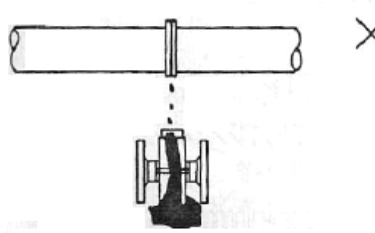
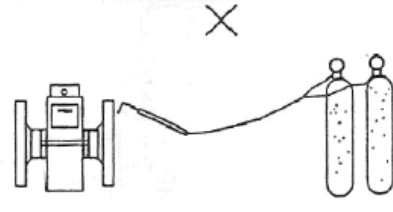
 <p>Proper overhang</p>	 <p>Install the converter for easy access</p>
 <p>Prevent strong sunshine</p>	 <p>Avoid large temperature difference</p>
 <p>Keep away from leaking</p>	 <p>Keep far away from fire</p>

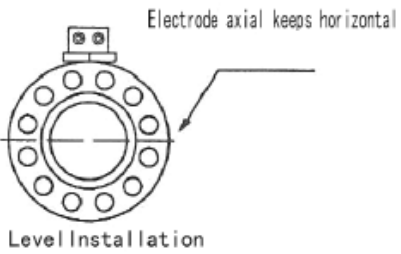
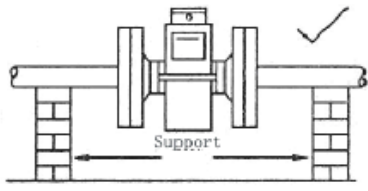
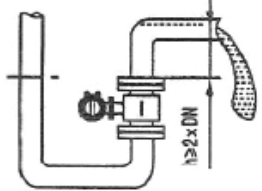
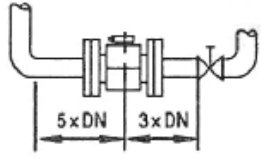
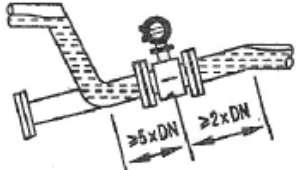
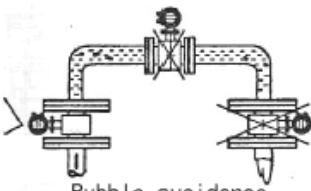
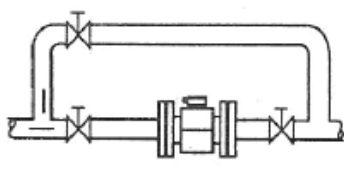
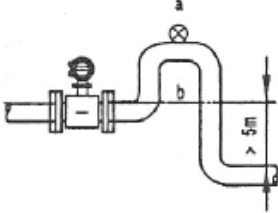
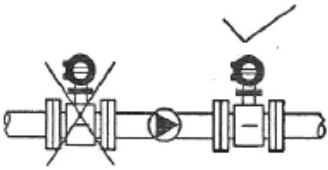
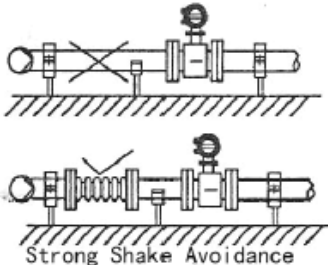
 <p>Electrode axial keeps horizontal</p> <p>Level Installation</p>	 <p>Support</p> <p>Reasonable Support</p>
 <p><math>\geq 2 \times DN</math></p> <p>Full of Pipe</p>	 <p><math>5 \times DN</math> <math>3 \times DN</math></p> <p>Ensure the Requir. of the Straight Pipe section</p>
 <p><math>\geq 5 \times DN</math> <math>\geq 2 \times DN</math></p> <p>Measurement for the Precipitable</p>	 <p>Bubble avoidance</p>
 <p>Bypass for easy maintenance and clean up</p>	 <p><math>5m</math></p> <p>Negative Pressure and Non-filled pipe Avoidance</p>
 <p>Not Installed in Front of the Inlet of Pump</p>	 <p>Strong Shake Avoidance</p>



15 Craig Road  
Acton, Massachusetts 01720  
United States of America  
Tel. +1 978 263 7100  
Fax +1 978 418 9170  
E-mail: [support@spiremt.com](mailto:support@spiremt.com)  
Website: [www.SpireMT.com](http://www.SpireMT.com)