



tPrime™ Series 280T-S

ULTRASONIC HEAT METER

Applications

- Residential submetering
- Commercial buildings
- District heating / cooling
- HVAC
- Green energy management
- AMR and Billing



Features

- Wear-free. Maintenance-free
- Unique sensor design for robust performance in both clear water and dirty water
- Multipath technology for increased accuracy
- Excellent long-term stability. Accuracy does not degrade over time
- Exceed OIML R75 class 2. Billing grade
- IP68 water-proof rated for the sensor, IP67 for the integrator
- Powered by both battery and MBus for extended lifespan
- For both heating and cooling circuits
- Free positioning
- Ready for AMR with M-Bus / Modbus / BACnet interface
- Low cost over extended lifespan
- Data Logger with 24 monthly totals
- SpireCapture AMR/AMI and Billing solutions



DS-280T-S_1704_Rev6



Spire Metering Technology LLC, 249 Cedar Hill Street, Marlborough, MA 01752, USA

Tel +1 978 263-7100 / 888 738-0188 (toll-free) **Fax** +1 978 418-9170 sales@spiremt.com www.SpireMT.com



tPrime™ Series 280T-S

ULTRASONIC HEAT METER

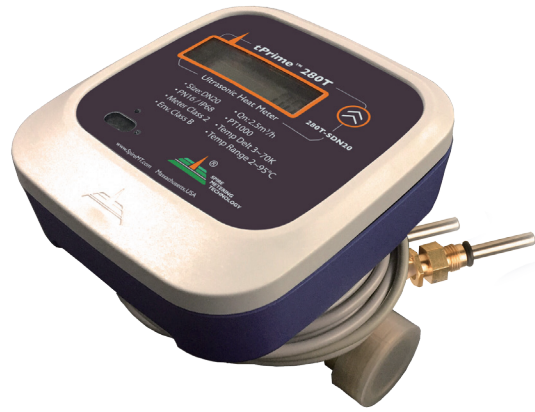

The tPrime™ series ultrasonic heat meter, often called BTU meter, offers the most advanced heating/cooling energy measurement by using state-of-the-art ultrasonic flow measurement technology. It does not have any moving parts that can wear or tear, thus, literally requires no maintenance.

With its maximum 200°F / 95°C water operating temperature and nominal pressure of 1.6MPa, the technical specifications of the tPrime™ series meet the standards for residential and commercial utility metering. The wide dynamic range allows for a load of up to double the rating, thereby ensuring high operation security. The large display can be set to display the heat consumption, temperature, flow total, working time, flow rate and more. The meter also has a remote readout which could be configured as M-Bus, RS485/Modbus, BACnet and more.

This new BTU meter system is powered by a lithium battery. However, whenever an MBus concentrator is connected, it will automatically draw power from the concentrator through the MBus connection. This unique feature extends the battery life of the meter.

The BTU calculation is according to the EN1434 heat meter standard. The formulas have been carefully implemented in the microprocessor to reduce the computational error to a minimum.

Spire Metering's ultrasonic BTU meter stands out among the competition due to its unique sensor design and multipath technology. It is able to work reliably even when the water is dirty. Both commercial and residential installations can profit from the advantages of the wear-free heating/cooling energy measurement, namely; precision, operation security and long service life.





tPrime™ Series 280T-S ULTRASONIC HEAT METER

Operating Principle

The tPrime™ series BTU meter is consisted of an ultrasonic flow sensor, a pair of PT1000 temperature sensors and an integrator. The microprocessor-based integrator controls the ultrasonic sensor to transmit and receive ultrasound in an orderly fashion so as to conduct precise flow measurement. It also has electronics dedicated to the PT1000 sensor to measure the temperature in the supply pipe as well as the return pipe. The integrator calculates the heat energy based on the flowrate and the temperature difference between the supply and the return.

The figure below illustrates how the thread type ultrasonic flow sensor works. Two ultrasonic transducers (A and B) are mounted on the flowcell body of the flow sensor, one is on the upstream and the other on the downstream. Two reflectors are used to direct the sound from one sensor to another. The integrator operates by alternately transmitting

and receiving a burst of sound energy between the two transducers and measuring the transit-time it takes for sound to travel between the two transducers. The difference in the transit-time measured corresponds directly to the velocity of the liquid in the pipe.

Unique Multi-path Technology

For large size meters, it is not easy to install the flow sensor perfectly in line with the pipe line. A small misalignment could cause flow profile distortion inside the flow sensor, thus, causing significant measurement errors. Spire Metering developed a unique multi-path technology to solve this problem. Two pairs of ultrasonic transducers are mounted on the flow sensor body to interrogate the flow from two different paths (refer to figure below.) A flow calculation algorithm based on fluid dynamics theory is then used to derive an average flow reading with improved accuracy.

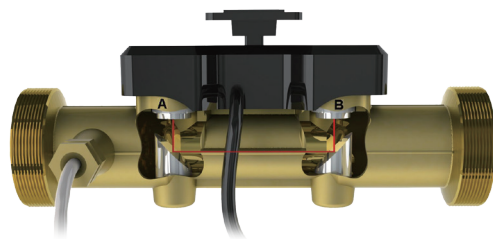

Thread Type (Small)

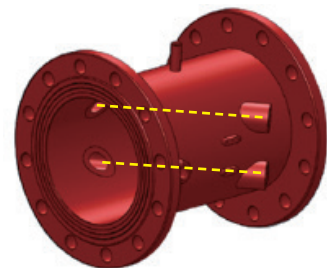

Flange Type (Large)



tPrime™ Series 280T-S

ULTRASONIC HEAT METER

Automatic Meter Reading

The tPrime™ series BTU meter offers a variety of interface options, such as M-Bus, RS485 with Modbus or BACnet. It is very flexible to be integrated into an AMR/AMI system.

Spire Metering also offers a complete range of AMR/AMI solutions as well as an integrated billing system. Its SpireCapture system is a cutting edge fixed automatic meter reading system which integrates both wired and wireless AMR/AMI technologies. It provides a unified platform for meter reading and data management through M-Bus and GPRS networks, as well as TCP/IP networks. In addition, it works seamlessly with Spire Metering’s billing software to make data exchange easy, fast and reliable.

SpireCapture is an advanced, highly robust meter reading solution that delivers comprehensive usage information as well as timely, high-resolution meter reading. This data enables gas, water, heat and electric utilities to eliminate on-site visits and estimated reads, reduce theft loss, implement time-of-use billing, and profit from all of the financial and operational benefits of fixed-network AMI/AMR.

A typical M-Bus based AMR system is illustrated in the below figure. It is consisted of a number of M-Bus utility meters, several M-Bus concentrators, a GPRS wireless modem for each concentrator and a data center. The concentrator communicates with the data center through a GPRS network. The data center first issues a meter reading command and sends it to the wireless network. The modem receives the command and forwards it to the M-Bus concentrator. Then, the concentrator either replies to the command with requested data or passes the command to its sub meters transparently.

For information on AMR/AMI parts, such as concentrators, repeaters, protocol convertors, data collection devices and etc., **please contact solutions@spiremt.com**

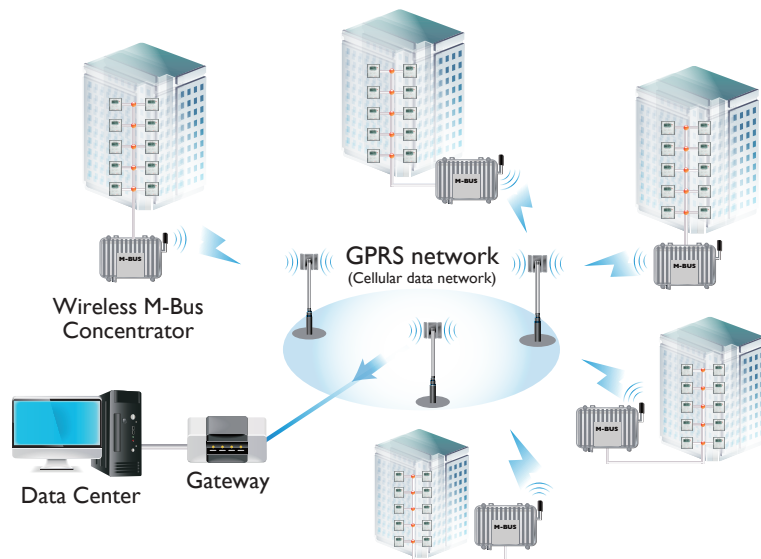



tPrime™ Series 280T-S

ULTRASONIC HEAT METER

Specifications

DN Size (mm)	Flowrate (m ³ /h)			Dimension (mm)			Weight* (kg)	Pipe Joint** (BSP / DIN)	
	Qmin	Qn	Qmax	L	W	H		Sensor	Ext.
DN15	0.03	1.5	3	110	120	100	1.2	G3/4B	G1/2B
DN20	0.05	2.5	5	130	120	105	1.2	G1B	G3/4B
DN25	0.07	3.5	7	160	120	110	1.6	G1 1/4B	G1B
DN32	0.12	6	12	180	120	120	2.2	G1 1/2B	G1 1/4B
DN40	0.2	10	20	200	120	125	2.8	G2B	G1 1/2B
DN50	0.6	15	30	200	165	197	10.8	4-M16	
DN65	1	25	50	200	185	211	14.5	4-M16	
DN80	1.6	40	80	225	200	227	16.9	8-M16	
DN100	2.4	60	120	250	220	247	19.9	8-M16	
DN125	4	100	200	250	250	242	26.2	8-M16	
DN150	6	150	300	300	285	277	29.0	8-M20	
DN200	10	250	500	350	340	327	48.9	12-M20	
DN250	16	400	800	450	405	412	93.9	12-M22	
DN300	24	600	1200	500	460	467	13.9	12-M22	

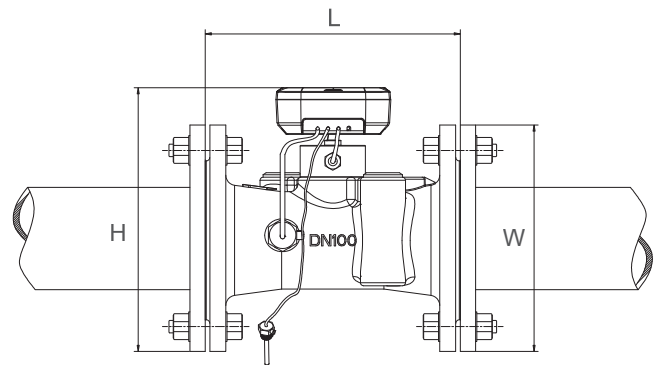
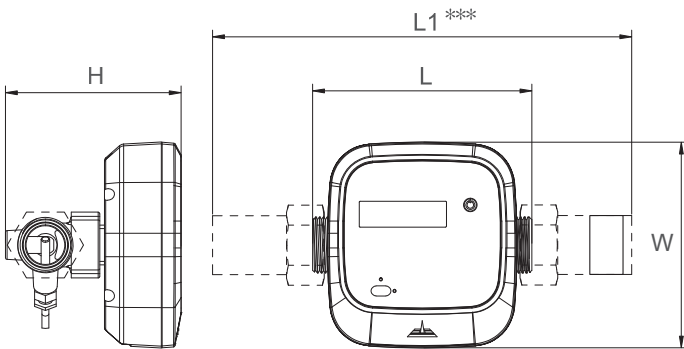

Notes:

*Weight may differ depending on accessories.

** For meters of size DN40 and smaller, the tail piece and thermal well of those meters could have threaded BSP or NPT joint.

The flange is standard DIN PN16 flange. ANSI flange is available upon request.

*** L1 equals L plus 94mm for DN15, 102mm for DN20, 121mm for DN25, 137mm for DN32 and 128mm for DN40.



tPrime™ Series 280T-S

ULTRASONIC HEAT METER

Electrical Data

Power Supply:	Battery, 3.6V, Lithium. Alternatively, the meter could be powered by MBus with current draw less than 3mA
Replacement Interval:	5 years at $t_{BAT} < 30^{\circ}C$ (86°F)
Power Consumption:	<0.2W
Standby Current:	<10uA
Backup Power Supply:	Internal SuperCap
Communication Interface:	M-Bus (default). Optional: RS485 with MODBUS or BACnet/MSTP
CE approval:	EN61326-1:2006

Accuracy / MPE (Maximum Permissible Error)

MPE according to OIML R75 / EN1434, the whole system error is the combination of the following:

$$\text{Calculator (Integrator): } E_c = \pm (0.5 + \Delta\Theta_{min} / \Delta\Theta)$$

$$\text{Temperature Sensor: } E_t = \pm (0.5 + 3\Delta\Theta_{min} / \Delta\Theta)$$

$$\text{Flow Sensor: } E_f = \pm (2 + 0.02 qp / q)$$

Here $\Delta\Theta$ is the temperature difference between the flow (supply) and return of the heat exchange circuit. q is the flow rate and qp is the nominal flow rate.

NOTE: The actual error of 280T-S meters is much smaller than the above MPE.

Calculator (Integrator)

Display:	LCD, 8 digits
Resolution:	999.99999 - 999999.99 - 99999999
Energy Unit:	KWh – MWh – GJ
Communication Protocol:	M-Bus (default). Optional: MODBUS or BACnet



tPrime™ Series 280T-S

ULTRASONIC HEAT METER

Temperature Measurement

Sensor Type: PT1000, 2-wire.
Sensor Measurement Range: 0~150°C (32~302°F)
Difference Range: $\Delta\Theta$: 3K-70K
Permissible Operating Θ : 2~60°C (35~140°F) for long term and up to 95°C (203°F) Temperature: for short term

Mechanical Data

Metrological Class: 2 (according to OIML R75 / EN1434)
Environmental Class: B
Electromagnetic Class: E1
Environmental Temp: 0-55°C (32-131°F)
Enclosure Protection: IP68 water-proof rated for the sensor, IP67 for the integrator
Integrator Detachable: Yes
Pressure: PN16
Flow Sensor Cable: 1.2m (5m length available)
Temperature Sensor Cable: 1.2m (5m length available)

Pressure Loss

The pressure loss of a flow sensor is proportional to the square on the flow: $\Delta p = k \times q^2$
Here Δp is pressure loss, q is volume flow rate and k is the coefficient.
All meters have Δp less than 0.25bar at q_p .



tPrime™ Series 280T-S

ULTRASONIC HEAT METER

Order Specifications

280T - SDN - - - - -

Size*	ID
DN15	015
DN20	020
DN25	025
DN32	032
DN40	040
DN50	050
DN65	065
DN80	080
DN100	100
DN125	125
DN150	150
DN200	200
DN250	250
DN300	300

Output Interface	ID
Serial TTL (opto-isolated)	0
M-Bus (Default)	1
RS485/Modbus	8
Pulse (OCT)	A

ID	Unit System
M	Metric (Default)
E	English / US Gal

ID	Pressure
1	1.6MPa (232 psig)

ID	Temperature
A	Standard Temperature

ID	Pipe Joint
A	BSP**
B	NPT (Meter body will have BSP threading with NPT Extension pieces)**
C	DIN Flange (Standard for DN50 and above)
D	ANSI Flange (Upon request for DN50 and above)

*Note: Larger sizes available upon request.

**Note: The thermal well will have the same threading.

Optional Adapter

(The Output Interface for the above main unit must be Serial TTL)

Output Interface Module	Model No.
BACnet / MSTP	280AP-MSTP
RS485 / Modbus	280AP-MOD
4-20mA+RS485 / Modbus	280AP-MODAO

Example

280T-SDN025-1-A-A-1-M

stands for the 280T-S tPrime™ series BTU meter for pipe DN25mm with M-Bus interface, BSP pipe joint (a pair of extension pieces and a T-connector thermowell are included). Standard pressure and temperature rating.

280T-SDN100-1-C-A-1-M

stands for the 280T-S tPrime™ series BTU meter for pipe DN100mm with M-Bus interface, DIN flange pipe joint, standard pressure and temperature rating.



tPrime™ Series 280T-S ULTRASONIC HEAT METER

Small size BTU meter (DN15-DN40)



- Integrator
- Interface Cable
- Flow Sensor Cable
- Temperature Sensor Cable

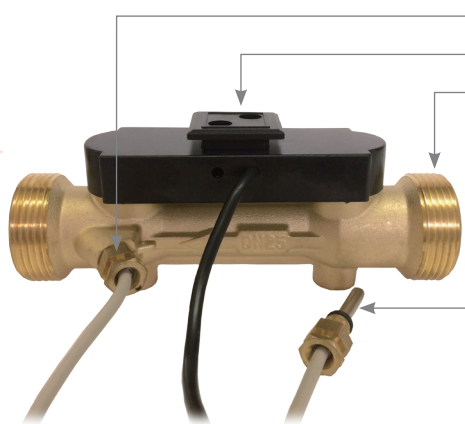

- Temperature Sensor 1 (already installed)
- Integrator Holder
- Flow Sensor
- Temperature Sensor 2

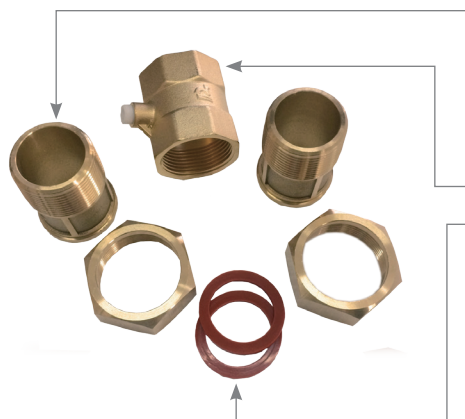

- Tail Piece / Extension Piece
- T-connector / Thermal well
- Gasket



tPrime™ Series 280T-S ULTRASONIC HEAT METER

Large Size BTU Meter (DN50 and DN65)





tPrime™ Series 280T-S

ULTRASONIC HEAT METER

Large Size BTU Meter (DN80-DN300)

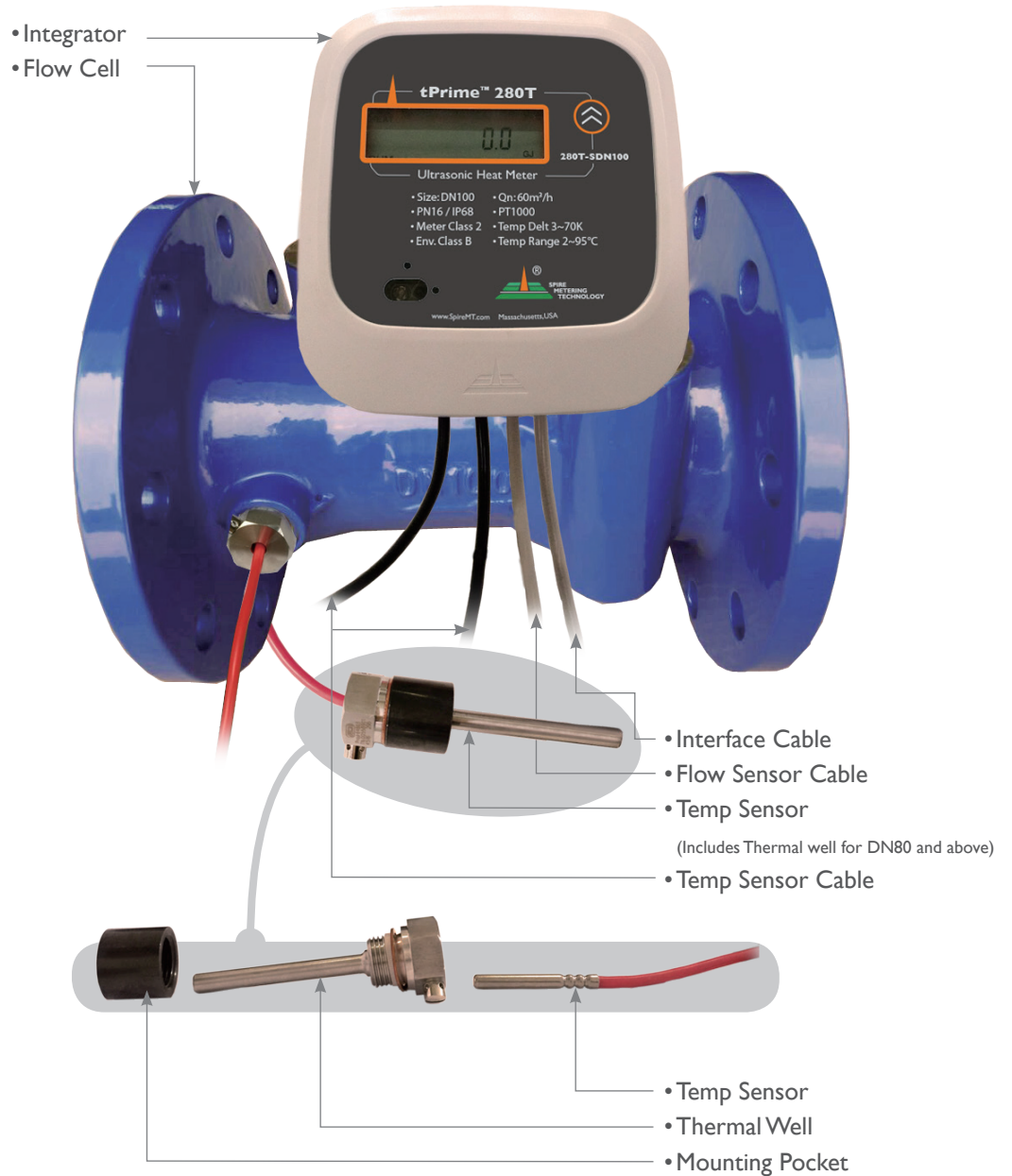



tPrime™ Series 280T-S

ULTRASONIC HEAT METER

Memo

About Spire Metering Technology

Spire Metering is a global leader in flow and energy management solutions. Through continuous innovation, we transform complex ultrasonic technology into affordable, reliable solutions for accurate flow and energy measurement. Spire Metering offers water, heat, and electricity meters as well as AMR/AMI solutions. To find out how we can help today, please tell us about your application.